



# ERP15-20VT

SPEC SHEET

1,500 - 2,000 kg

---

VT Series

---

Electric Forklift Trucks

## VDI 2198 – GENERAL SPECIFICATIONS – VT SERIES

		Yale					
		ERP 15VT (SWB)	ERP 16VT (SWB)	ERP 16VT (MWB)	ERP 16VT (LWB)		
<b>GENERAL</b>	1.1	Manufacturer					
	1.2	Model designation					
	1.3	Drive	Electric (battery)				
	1.4	Operator type	Seated				
	1.5	Rated capacity/rated load	Q (t)	1.5	1.6		
	1.6	Load centre distance	c (mm)	500			
	1.8	Load distance, centre of drive axle to fork	x (mm)	326			
	1.9	Wheelbase	y (mm)	1290	1290	1386	1494
	<b>WEIGHT</b>	2.1	Service weight <sup>(1)</sup>	kg	2971	3083	
2.2		Axle loading, laden front/rear <sup>(1)</sup>	kg	3892 / 580	4096 / 587	4050 / 633	4056 / 802
2.3		Axle loading, unladen front/rear <sup>(1)</sup>	kg	1430 / 1541	1470 / 1613	1495 / 1588	1571 / 1687
<b>TYRES</b>	3.1	Tyres front/rear	Superelastic				
	3.2	Tyre size, front	18 x 7-8				
	3.3	Tyre size, rear	15 x 4,5-8				
	3.5	Wheels, number front/rear (x = driven wheels)	2X / 2				
	3.6	Tread, front	b <sub>10</sub> (mm)	889			
	3.7	Tread, rear	b <sub>11</sub> (mm)	194			
	<b>DIMENSIONS</b>	4.1	Tilt of mast/fork carriage forward/backward	$\alpha / \beta$ (°)	5 / 5		
4.2		Height, mast lowered	h <sub>1</sub> (mm)	2230			
4.3		Free lift <sup>(2)</sup>	h <sub>2</sub> (mm)	100			
4.4		Lift <sup>(2)</sup>	h <sub>3</sub> (mm)	3320			
4.5		Height, mast extended <sup>(3)</sup>	h <sub>4</sub> (mm)	3898			
4.7		Height of overhead guard (cabin) <sup>(4)</sup>	h <sub>6</sub> (mm)	2070			
4.7.1		Cab height (open cab)		2085			
4.8		Seat height relating to SIP/stand height <sup>(5)</sup>	h <sub>7</sub> (mm)	919			
4.12		Coupling height	h <sub>10</sub> (mm)	500			
4.19		Overall length	l <sub>1</sub> (mm)	2807	2903		3011
4.20		Length to face of forks	l <sub>2</sub> (mm)	1807	1903		2011
4.21		Overall width <sup>(6)</sup>	b <sub>1</sub> /b <sub>2</sub> (mm)	1050 <sup>(6)</sup>			
4.22		Fork dimensions ISO 2331	s/e/l (mm)	40 / 80 / 1000			
4.23		Fork carriage ISO 2328, class/type A, B		2A			
4.24		Fork carriage width <sup>(7)</sup>	b <sub>3</sub> (mm)	907			
4.31		Ground clearance, laden, below mast	m <sub>1</sub> (mm)	70			
4.32		Ground clearance at centre of wheelbase <sup>(8)</sup>	m <sub>2</sub> (mm)	100			
4.33		Load dimension b <sub>12</sub> x l <sub>6</sub> crossways	b <sub>12</sub> x l <sub>6</sub> (mm)	1000 x 1200			
4.34		Aisle width predetermined load dimensions	Ast (mm)	3134	3232		3340
4.34.1		Aisle width for pallets 1000 x 1200 crossways	Ast (mm)	3134	3232		3340
4.34.2		Aisle width for pallets 800 x 1200 lengthways	Ast (mm)	3257	3355		3463
4.35		Turning radius	Wa (mm)	1479	1577		1685
4.36		Internal turning radius	b <sub>13</sub> (mm)	0			
4.41	90° intersecting aisle (With pallet W = 1200mm, L = 1000mm)	mm	1718	1754		1798	
4.42	Step Height (from ground to running board)	mm	557				
4.43	Step Height	mm	484				
<b>PERFORMANCE</b>	5.1	Travel speed, laden/unladen <sup>(9)</sup>	km/h	16 / 16			
	5.1.1	Travel speed, laden/unladen, backwards	km/h	16 / 16			
	5.2	Lift speed, laden/unladen	m/s	0.43 / 0.59			
	5.3	Lowering speed, laden/unladen	m/s	0.50 / 0.47			
	5.5	Drawbar pull, laden/unladen <sup>(10)</sup>	N	3406 / 3680			
	5.6	Max. drawbar pull, laden/unladen <sup>(11)</sup>	N	11415 / 11690			
	5.7	Gradeability, laden/unladen <sup>(12)</sup>	%	11 / 16			
	5.8	Max. gradeability, laden/unladen <sup>(11)</sup>	%	25 / 34	25 / 35		
	5.9	Acceleration time, laden/unladen <sup>(9)</sup>	s	4.6 / 4.1			
	5.10	Service brake		Electric			
<b>ELECTRIC</b>	6.1	Drive motor rating S2 60 min	kW	2 x 5.0			
	6.2	Lift motor rating at S3 15%	kW	12			
	6.3	Battery according to DIN 43531/35/36 A, B, C, no		DIN 43531-A			
	6.4	Battery voltage/nominal capacity K5	(V)/(ah)	48 / 500	48 / 625		48 / 750
	6.5	Battery weight <sup>(13)</sup>	kg	673 / 743		813 / 899	962 / 1064
	6.6	Energy consumption according to VDI cycle <sup>(14)</sup>	kWh/h @ no. of cycles	3.9	4.2		
<b>OTHER</b>	8.1	Type of drive unit	Electric transmission				
	10.1	Operating pressure for attachments	bar	180			
	10.2	Oil volume for attachments <sup>(15)</sup>	l/min	40			
	10.3	Hydraulic oil tank, capacity	l	16.8			
	10.7	Sound pressure level at the driver's seat LPAZ <sup>(16)</sup>	dB(A)	69			
	10.8	Towing coupling, type DIN		Pin			

(1) Max. battery

(2) Bottom of forks

(3) Without load backrest

(4) h<sub>6</sub> subject to +/- 5mm tolerance

(5) Full suspension seat specified. Standard hood specified. 953mm with raised hood

(6) Overall width 1116mm with required 200/50-10 tyres fitted for masts 5000mm and over

(7) Add 32mm with load backrest

(8) Value shown for vertical battery removal; horizontal battery removal has 90mm of clearance at center of wheelbase

(9) HiP performance

**All values are nominal values and they are subject to tolerances.**

## VDI 2198 – GENERAL SPECIFICATIONS – VT SERIES

		Yale				
		ERP 18VT (MWB)	ERP 18VT (LWB)	ERP 20VT (MWB)	ERP 20VT (LWB)	
GENERAL	1.1	Manufacturer				
	1.2	Model designation				
	1.3	Drive	Electric (battery)			
	1.4	Operator type	Seated			
	1.5	Rated capacity/rated load	Q (t)		1.8	
	1.6	Load centre distance	c (mm)			
	1.8	Load distance, centre of drive axle to fork	x (mm)			
	1.9	Wheelbase	y (mm)		321	
			1386	1494	1386	1494
WEIGHT	2.1	Service weight <sup>(1)</sup>	kg			
	2.2	Axle loading, laden front/rear <sup>(1)</sup>	kg			
	2.3	Axle loading, unladen front/rear <sup>(1)</sup>	kg			
		3335	3331	3602	3436	
		4496 / 640	4435 / 695	4941 / 661	4788 / 648	
		1628 / 1707	1646 / 1685	1755 / 1847	1689 / 1747	
TYRES	3.1	Tyres front/rear	Superelastic			
	3.2	Tyre size, front	200 / 50-10			
	3.3	Tyre size, rear	15 x 4,5-8			
	3.5	Wheels, number front/rear (x = driven wheels)	2X / 2			
	3.6	Tread, front	b <sub>10</sub> (mm)			
	3.7	Tread, rear	b <sub>11</sub> (mm)			
			908			
		194				
DIMENSIONS	4.1	Tilt of mast/fork carriage forward/backward	α / β (°)			
	4.2	Height, mast lowered	h <sub>1</sub> (mm)			
	4.3	Free lift <sup>(2)</sup>	h <sub>2</sub> (mm)			
	4.4	Lift <sup>(2)</sup>	h <sub>3</sub> (mm)			
	4.5	Height, mast extended <sup>(3)</sup>	h <sub>4</sub> (mm)			
	4.7	Height of overhead guard (cabin) <sup>(4)</sup>	h <sub>6</sub> (mm)			
	4.7.1	Cab height (open cab)	2070			
	4.8	Seat height relating to SIP/stand height <sup>(5)</sup>	h <sub>7</sub> (mm)			
	4.12	Coupling height	h <sub>10</sub> (mm)			
	4.19	Overall length	l <sub>1</sub> (mm)			
	4.20	Length to face of forks	l <sub>2</sub> (mm)			
	4.21	Overall width <sup>(6)</sup>	b <sub>1</sub> /b <sub>2</sub> (mm)			
	4.22	Fork dimensions ISO 2331	s/e/l (mm)			
	4.23	Fork carriage ISO 2328, class/type A, B	2A			
	4.24	Fork carriage width <sup>(7)</sup>	b <sub>3</sub> (mm)			
	4.31	Ground clearance, laden, below mast	m <sub>1</sub> (mm)			
	4.32	Ground clearance at centre of wheelbase <sup>(8)</sup>	m <sub>2</sub> (mm)			
	4.33	Load dimension b <sub>12</sub> × l <sub>6</sub> crossways	b <sub>12</sub> × l <sub>6</sub> (mm)			
	4.34	Aisle width predetermined load dimensions	A <sub>st</sub> (mm)			
	4.34.1	Aisle width for pallets 1000 × 1200 crossways	3228			
	4.34.2	Aisle width for pallets 800 × 1200 lengthways	3336			
	4.35	Turning radius	Wa (mm)			
	4.36	Internal turning radius	b <sub>13</sub> (mm)			
4.41	90° intersecting aisle (With pallet W = 1200mm, L = 1000mm)	mm				
4.42	Step Height (from ground to running board)	mm				
4.43	Step Height	mm				
		2898				
		1898				
		1116				
		40 / 80 / 1000				
		2A				
		977				
		70				
		100				
		1000 x 1200				
		3228				
		3336				
		3350				
		1577				
		0				
		1776				
		1820				
		1776				
		1820				
		557				
		484				
PERFORMANCE	5.1	Travel speed, laden/unladen <sup>(9)</sup>	km/h			
	5.1.1	Travel speed, laden/unladen, backwards	km/h			
	5.2	Lift speed, laden/unladen	m/s			
	5.3	Lowering speed, laden/unladen	m/s			
	5.5	Drawbar pull, laden/unladen <sup>(10)</sup>	N			
	5.6	Max. drawbar pull, laden/unladen <sup>(11)</sup>	N			
	5.7	Gradeability, laden/unladen <sup>(12)</sup>	%			
	5.8	Max. gradeability, laden/unladen <sup>(11)</sup>	%			
	5.9	Acceleration time, laden/unladen <sup>(9)</sup>	s			
	5.10	Service brake	Electric			
		16 / 16				
		16 / 16				
		0.41 / 0.60		0.40 / 0.58		
		0.46 / 0.40		0.47 / 0.40		
		3337 / 3646		3260 / 3603		
		3294 / 3637		3294 / 3637		
		11355 / 11664		11346 / 11655		
		10 / 15		9 / 14		
		23 / 35		23 / 36		
		31 / 34		22 / 36		
		4.6 / 4.1				
ELECTRIC	6.1	Drive motor rating S2 60 min	kW			
	6.2	Lift motor rating at S3 15%	kW			
	6.3	Battery according to DIN 43531/35/36 A, B, C, no	DIN 43531-A			
	6.4	Battery voltage/nominal capacity K5	(V)/(ah)			
	6.5	Battery weight <sup>(13)</sup>	kg			
	6.6	Energy consumption according to VDI cycle <sup>(14)</sup>	kWh/h			
			@ no. of cycles			
		2x 5.0				
		12				
		48 / 625				
		48 / 750				
		48 / 625				
		48 / 750				
		813 / 899		962 / 1064		
		813 / 899		962 / 1064		
		4.7		4.7		
		5.5		5.2		
OTHER	8.1	Type of drive unit	Electric transmission			
	10.1	Operating pressure for attachments	bar			
	10.2	Oil volume for attachments <sup>(15)</sup>	l/min			
	10.3	Hydraulic oil tank, capacity	l			
	10.7	Sound pressure level at the driver's seat LPAZ <sup>(16)</sup>	dB(A)			
	10.8	Towing coupling, type DIN	Pin			
		180				
		40				
		16.8				
		69				
		Pin				

(10) 60 minute rating

(11) 5 minute rating

(12) 30 minute rating

(13) Min./max.

(14) eLo performance

(15) Maximum flow set through dash display

(16) LPAZ, measured according to the test cycles and based on the weighting values contained in EN12053

**Spec sheet truck based on:** 3360mm (Clear View) and 3430mm (Hi-Vis) to top of fork, 2 stage LFL mast with standard carriage and 1000mm forks, with HIP performance setting, DIN battery configuration

# TRUCK DIMENSIONS – VT SERIES

$$A_{st} = Wa + R + a = Wa + \sqrt{(l_6 + x)^2 + (b_{12}/2 - b_{13})^2} + a$$

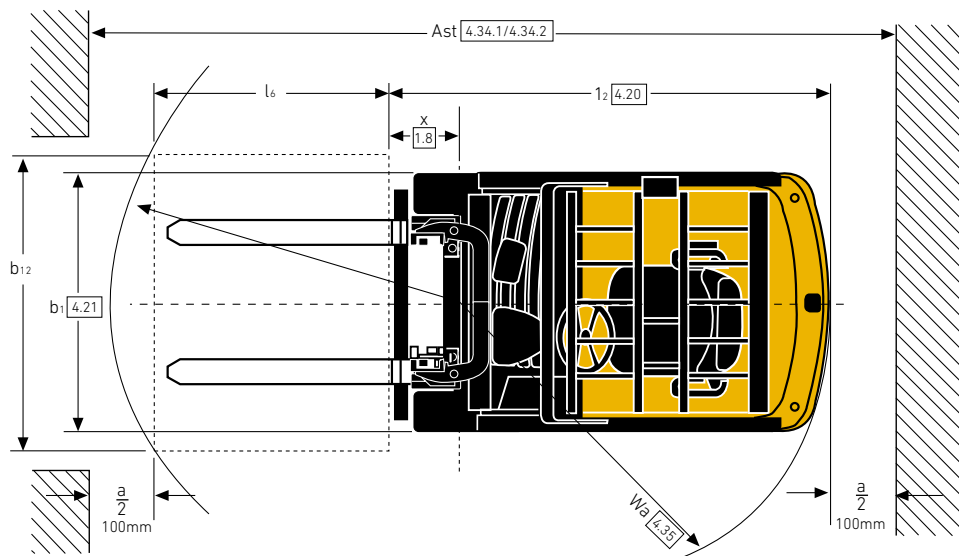
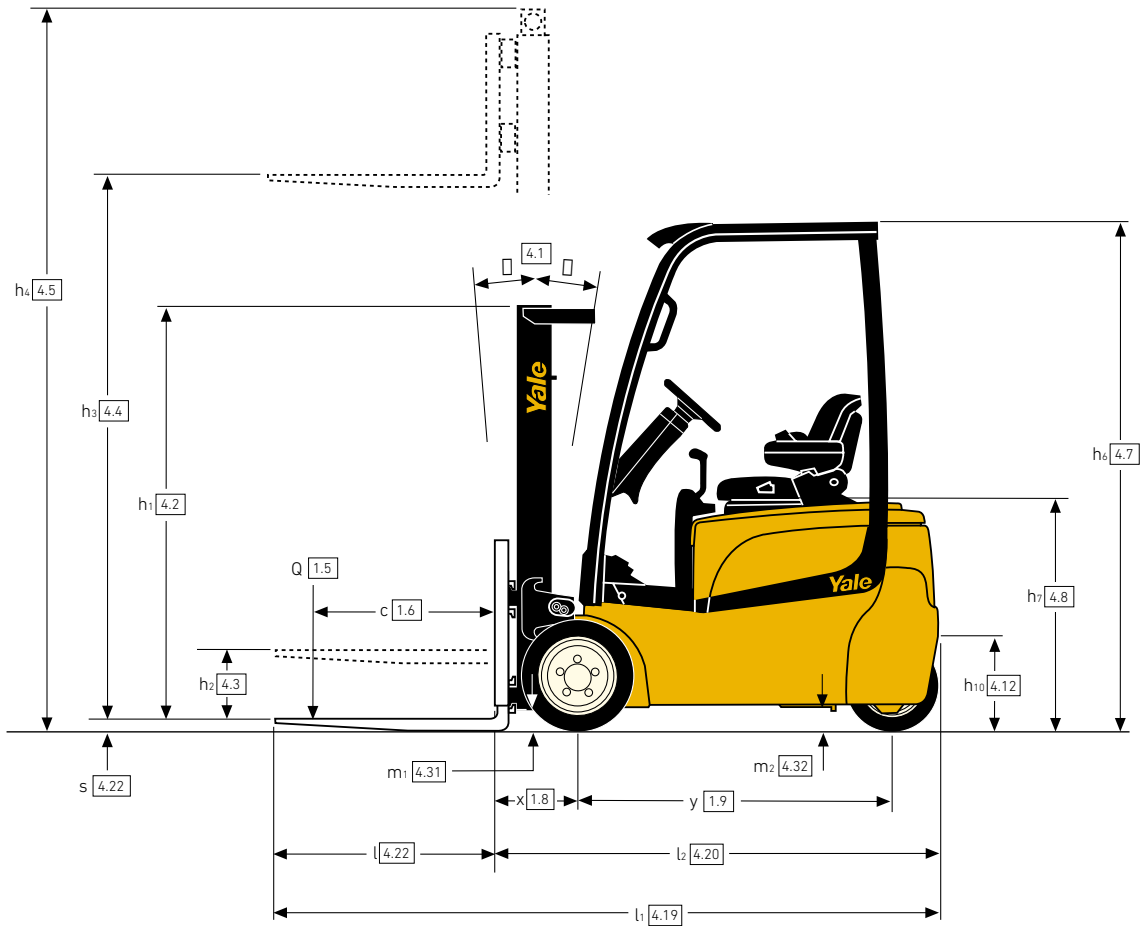

## MAST DIMENSIONS – ERP 15VT SWB

h <sub>1</sub> (mm)	h <sub>2+s</sub> (mm)	h <sub>3+s</sub> (mm)	h <sub>4</sub> (mm)	Tilt		Forks			Integral sideshift		
						Load centre (kg)			Load centre (kg)		
				F	B	500	600	700	500	600	700
<b>2-Stage Limited Free-Lift (LFL) Clear View</b>											
2230	140	3360	3868	5	5	1500	1300	1300	1500	1300	1250
2580	140	3860	4368	5	5	1500	1300	1300	1500	1300	1250
2830	140	4360	4868	5	5	1480	1280	1280	1480	1280	1230
3180	140	4860	5368	5	5	1390	1210	1200	1390	1210	1150
<b>2-Stage Full Free-Lift (FFL) Hi-Vis</b>											
2080	1505	3218	3728	5	5	1500	1300	1300	1500	1300	1250
2330	1755	3718	4228	5	5	1500	1300	1300	1500	1300	1240
2680	2105	4338	4847	5	5	1500	1300	1300	1500	1300	1240
<b>3-Stage Full Free-Lift (FFL) Mast Clear View</b>											
1980	1472	4300	4808	5	5	1500	1300	1300	1500	1300	1230
2080	1572	4600	5108	5	5	1450	1250	1250	1450	1250	1190
2180	1672	4900	5408	5	5	1390	1210	1200	1390	1210	1140
2330	1822	5200 <sup>(1)</sup>	5708	5	5	1340	1160	1150	1340	1160	1090
2430	1922	5500 <sup>(1)</sup>	6008	5	5	1280	1110	1100	1240	1110	1040

(1) Tilt speed reduced to 1° per second by mechanical tilt speed restrictors for mast heights 5000mm and above

All ratings with DIN Battery

All ratings with 1000mm forks and less load backrest

Note that the capacities are given in kilograms

## MAST DIMENSIONS – ERP 16VT SWB/MWB

h <sub>1</sub> (mm)	h <sub>2+s</sub> (mm)	h <sub>3+s</sub> (mm)	h <sub>4</sub> (mm)	Tilt		Forks			Integral sideshift			Forks			Integral sideshift		
						Load centre (kg)			Load centre (kg)			Load centre (kg)			Load centre (kg)		
				F	B	500	600	700	500	600	700	500	600	700	500	600	700
<b>2-Stage Limited Free-Lift (LFL) Clear View</b>																	
2230	140	3360	3868	5	5	1600	1450	1390	1600	1450	1330	1600	1450	1450	1600	1450	1450
2580	140	3860	4368	5	5	1600	1450	1380	1600	1450	1330	1600	1450	1450	1600	1450	1450
2830	140	4360	4868	5	5	1580	1430	1360	1580	1430	1310	1580	1430	1430	1580	1430	1430
3180	140	4860	5368	5	5	1490	1350	1280	1490	1350	1230	1490	1350	1350	1490	1350	1350
<b>2-Stage Limited Free-Lift (LFL) Hi-Vis</b>																	
2180	140	3432	4006	5	5	1600	1450	1390	1600	1450	1320	1600	1450	1390	1600	1450	1320
2530	140	3932	4506	5	5	1600	1450	1380	1600	1450	1310	1600	1450	1380	1600	1450	1310
2780	140	4432	5006	5	5	1580	1430	1370	1580	1430	1300	1580	1430	1370	1580	1430	1300
3130	140	4932	5506	5	5	1490	1350	1280	1490	1340	1220	1490	1350	1280	1490	1340	1220
<b>2-Stage Full Free-Lift (FFL) Hi-Vis</b>																	
2080	1505	3218	3728	5	5	1600	1450	1400	1600	1450	1330	1600	1450	1400	1600	1450	1330
2330	1755	3718	4228	5	5	1600	1450	1390	1600	1450	1320	1600	1450	1390	1600	1450	1320
2680	2105	4338	4847	5	5	1600	1450	1380	1580	1440	1310	1600	1450	1380	1600	1450	1310
<b>3-Stage Full Free-Lift (FFL) Clear View</b>																	
1980	1472	4300	4808	5	5	1600	1450	1380	1590	1450	1310	1600	1450	1380	1600	1450	1310
2080	1572	4600	5108	5	5	1540	1400	1330	1540	1400	1270	1540	1400	1330	1540	1400	1260
2180	1672	4900	5408	5	5	1490	1350	1280	1490	1350	1220	1490	1350	1280	1490	1340	1220
2330	1822	5200 <sup>(1)</sup>	5708	5	5	1430	1300	1230	1360	1290	1170	1320	1300	1230	1250	1250	1170
2430	1922	5500 <sup>(1)</sup>	6008	5	5	1130	1130	1130	1070	1070	1070	1060	1060	1060	1000	1000	1000
<b>3-Stage Full Free-Lift (FFL) Hi-Vis</b>																	
1930	1355	4300	4875	5	5	1600	1450	1380	1590	1450	1310	1600	1450	1380	1600	1450	1310
2030	1455	4600	5175	5	5	1570	1420	1360	1550	1420	1290	1570	1420	1360	1570	1420	1290
2130	1555	4900	5375	5	5	1520	1370	1310	1510	1370	1240	1520	1370	1310	1520	1370	1240
2280	1705	5200 <sup>(1)</sup>	5775	5	5	1380	1320	1260	1320	1310	1190	1260	1260	1260	1200	1200	1190
2380	1805	5500 <sup>(1)</sup>	6075	5	5	1090	1090	1090	1030	1030	1030	1000	1000	1000	950	950	950

(1) Tilt speed reduced to 1° per second by mechanical tilt speed restrictors for mast heights 5000mm and above

All ratings with DIN Battery

All ratings with 1000mm forks and less load backrest

Note that the capacities are given in kilograms

All values are nominal values and they are subject to tolerances.

## MAST DIMENSIONS – ERP 16VT LWB

h <sub>1</sub> (mm)	h <sub>2+s</sub> (mm)	h <sub>3+s</sub> (mm)	h <sub>4</sub> (mm)	Tilt		Forks			Integral sideshift		
						Load centre (kg)			Load centre (kg)		
						500	600	700	500	600	700
<b>2-Stage Limited Free-Lift (LFL) Clear View</b>											
2230	140	3360	3868	5	5	1600	1450	1390	1600	1450	1330
2580	140	3860	4368	5	5	1600	1450	1380	1600	1450	1330
2830	140	4360	4868	5	5	1580	1430	1360	1580	1430	1310
3180	140	4860	5368	5	5	1500	1360	1290	1500	1360	1240
<b>2-Stage Limited Free-Lift (LFL) Hi-Vis</b>											
2180	140	3432	4006	5	5	1600	1450	1390	1600	1450	1320
2530	140	3932	4506	5	5	1600	1450	1380	1600	1450	1310
2780	140	4432	5006	5	5	1580	1430	1370	1580	1430	1300
3130	140	4932	5506	5	5	1500	1360	1290	1500	1350	1220
<b>2-Stage Full Free-Lift (FFL) Hi-Vis</b>											
2080	1505	3218	3728	5	5	1600	1450	1400	1600	1450	1330
2330	1755	3718	4228	5	5	1600	1450	1390	1600	1450	1320
2680	2105	4338	4847	5	5	1600	1450	1380	1600	1450	1310
<b>3-Stage Full Free-Lift (FFL) Clear View</b>											
1980	1472	4300	4808	5	5	1600	1450	1370	1600	1440	1310
2080	1572	4600	5108	5	5	1550	1400	1330	1550	1400	1260
2180	1672	4900	5408	5	5	1500	1360	1280	1500	1350	1220
2330	1822	5200 <sup>(1)</sup>	5708	5	5	1330	1310	1230	1260	1260	1170
2430	1922	5500 <sup>(1)</sup>	6008	5	5	1080	1080	1080	1010	1010	1010
<b>3-Stage Full Free-Lift (FFL) Hi-Vis</b>											
1930	1355	4300	4875	5	5	1600	1450	1380	1600	1450	1310
2030	1455	4600	5175	5	5	1570	1420	1360	1570	1420	1290
2130	1555	4900	5375	5	5	1520	1380	1310	1520	1370	1240
2280	1705	5200 <sup>(1)</sup>	5775	5	5	1280	1280	1260	1210	1210	1200
2380	1805	5500 <sup>(1)</sup>	6075	5	5	1030	1030	1030	970	970	970

(1) Tilt speed reduced to 1° per second by mechanical tilt speed restrictors for mast heights 5000mm and above

All ratings with DIN Battery

All ratings with 1000mm forks and less load backrest

Note that the capacities are given in kilograms

## MAST DIMENSIONS – ERP 18VT MWB/LWB

h <sub>1</sub> (mm)	h <sub>2+s</sub> (mm)	h <sub>3+s</sub> (mm)	h <sub>4</sub> (mm)	Tilt		Forks			Integral sideshift			Forks			Integral sideshift		
						Load centre (kg)			Load centre (kg)			Load centre (kg)			Load centre (kg)		
						500	600	700	500	600	700	500	600	700	500	600	700
<b>2-Stage Limited Free-Lift (LFL) Hi-Vis</b>																	
2180	140	3432	4006	5	5	1800	1600	1550	1800	1600	1470	1800	1600	1550	1800	1600	1470
2530	140	3932	4506	5	5	1800	1600	1540	1800	1600	1470	1800	1600	1540	1800	1600	1470
2780	140	4432	5006	5	5	1780	1580	1530	1780	1580	1450	1780	1580	1530	1780	1580	1450
3130	140	4932	5506	5	5	1580	1500	1440	1540	1500	1370	1580	1500	1440	1540	1500	1370
<b>2-Stage Full Free-Lift (FFL) Hi-Vis</b>																	
2080	1505	3218	3728	5	5	1800	1600	1560	1800	1600	1480	1800	1600	1560	1800	1600	1480
2330	1755	3718	4228	5	5	1800	1600	1550	1800	1600	1470	1800	1600	1550	1800	1600	1470
2680	2105	4338	4847	5	5	1800	1600	1540	1800	1600	1470	1800	1600	1540	1800	1600	1470
<b>3-Stage Full Free-Lift (FFL) Hi-Vis</b>																	
1930	1355	4300	4875	5	5	1800	1600	1540	1800	1600	1470	1800	1600	1540	1800	1600	1470
2030	1455	4600	5175	5	5	1770	1570	1520	1770	1570	1440	1770	1570	1520	1770	1570	1440
2130	1555	4900	5375	5	5	1710	1520	1470	1710	1520	1390	1710	1520	1470	1710	1520	1390
2280	1705	5200 <sup>(1)</sup>	5775	5	5	1650	1470	1410	1650	1470	1340	1650	1470	1410	1650	1470	1340
2380	1805	5500 <sup>(1)</sup>	6075	5	5	1590	1410	1350	1550	1410	1290	1440	1410	1350	1370	1370	1280

(1) Tilt speed reduced to 1° per second by mechanical tilt speed restrictors for mast heights 5000mm and above

All ratings with DIN Battery

All ratings with 1000mm forks and less load backrest

Note that the capacities are given in kilograms

## MAST DIMENSIONS – ERP 20VT MWB/LWB

h <sub>1</sub> (mm)	h <sub>2+s</sub> (mm)	h <sub>3+s</sub> (mm)	h <sub>4</sub> (mm)	Tilt		Forks			Integral sideshift			Forks			Integral sideshift		
				F	B	Load centre (kg)			Load centre (kg)			Load centre (kg)			Load centre (kg)		
						500	600	700	500	600	700	500	600	700	500	600	700
<b>2-Stage Limited Free-Lift (LFL) Hi-Vis</b>																	
2180	140	3432	4006	5	5	2000	1800	1700	1990	1780	1620	2000	1800	1700	1990	1780	1610
2530	140	3932	4506	5	5	2000	1800	1690	1980	1780	1610	2000	1800	1690	1980	1770	1610
2780	140	4432	5006	5	5	1980	1780	1680	1950	1760	1590	1980	1780	1670	1950	1760	1590
3130	140	4932	5506	5	5	1570	1570	1570	1520	1520	1510	1560	1560	1560	1520	1520	1500
<b>2-Stage Full Free-Lift (FFL) Hi-Vis</b>																	
2080	1505	3218	3728	5	5	2000	1800	1710	2000	1790	1620	2000	1800	1700	2000	1790	1620
2330	1755	3718	4228	5	5	2000	1800	1700	1990	1790	1620	2000	1800	1700	1990	1780	1610
2680	2105	4338	4847	5	5	2000	1800	1690	1960	1780	1610	2000	1800	1690	1980	1770	1610
<b>3-Stage Full Free-Lift (FFL) Hi-Vis</b>																	
1930	1355	4300	4875	5	5	2000	1800	1690	1970	1780	1610	2000	1800	1690	1980	1770	1610
2030	1455	4600	5175	5	5	1970	1770	1670	1930	1750	1580	1970	1770	1660	1950	1740	1580
2130	1555	4900	5375	5	5	1780	1720	1620	1720	1700	1540	1910	1710	1610	1880	1690	1530
2280	1705	5200 <sup>(1)</sup>	5775	5	5	1490	1490	1490	1440	1440	1440	1670	1660	1550	1600	1590	1470
2380	1805	5500 <sup>(1)</sup>	6075	5	5	1250	1250	1250	1200	1200	1200	1420	1420	1410	1360	1360	1350

(1) Tilt speed reduced to 1° per second by mechanical tilt speed restrictors for mast heights 5000mm and above

All ratings with DIN Battery

All ratings with 1000mm forks and less load backrest

Note that the capacities are given in kilograms

**All values are nominal values and they are subject to tolerances.**



# About Yale®

Yale Lift Truck Technologies leverages over a century of material handling experience and substantial investment in innovation to bring the most advanced technology-driven lift truck solutions to market. The company offers a full line of award-winning lift trucks, including reach trucks, order pickers, turret trucks, pallet jacks and trucks, pallet stackers, tow tractors and counterbalanced forklifts, as well as powerful operator assist solutions, proven robotics and a wide range of power sources to help customers adapt to today's demanding supply chain. Yale and its independent dealer network support these solutions with comprehensive after-sales service, parts, financing and training.

Yale Lift Truck Technologies is a trading name of Hyster-Yale Asia-Pacific Pty Ltd., a wholly owned subsidiary of Hyster-Yale Materials Handling, Inc.(NYSE:HY) which is headquartered in Cleveland, Ohio and operates globally.

## MATERIALS HANDLING FOR:

Third-party logistics (3PL)

Auto parts distribution

Beverage

Cold & frozen foods

Food distribution

Food processing

Furniture & furnishings

Government

Health & pharma

Home centers

Retail & e-commerce

Yale Lift Truck Technologies | Pacific  
1/23 Rowood Road  
Prospect NSW 2148

Yale Lift Truck Technologies | Asia  
16 Tuas Avenue 20  
Singapore 638827

**[yale.com](http://yale.com)**

© 2023 Hyster-Yale Group, Inc., all rights reserved. YALE and  are trademarks of Hyster-Yale Group, Inc. Trucks may be shown with optional equipment and/or features not available in all regions. Specifications and details in this brochure are subject to change without prior notification.