

VF series

Electric forklift trucks

1,600kg / 1,800kg / 2,000kg

- YaleStop automatic park brake eliminates uncontrolled roll-back on ramps
- Oil-immersed brakes
- CANbus and high-performance AC motor technology
- E-steering to increase productivity while maintaining excellent battery life
- New 180° fold back door and fork pockets allow completing horizontal battery exchange in 3 min
- 2 battery choices: DIN and BS



Truck Dimensions

$$Ast = Wa + R + a = Wa + \sqrt{(l_6 + x)^2 + (b_{12}/2 - b_{13}/2)^2} + a$$

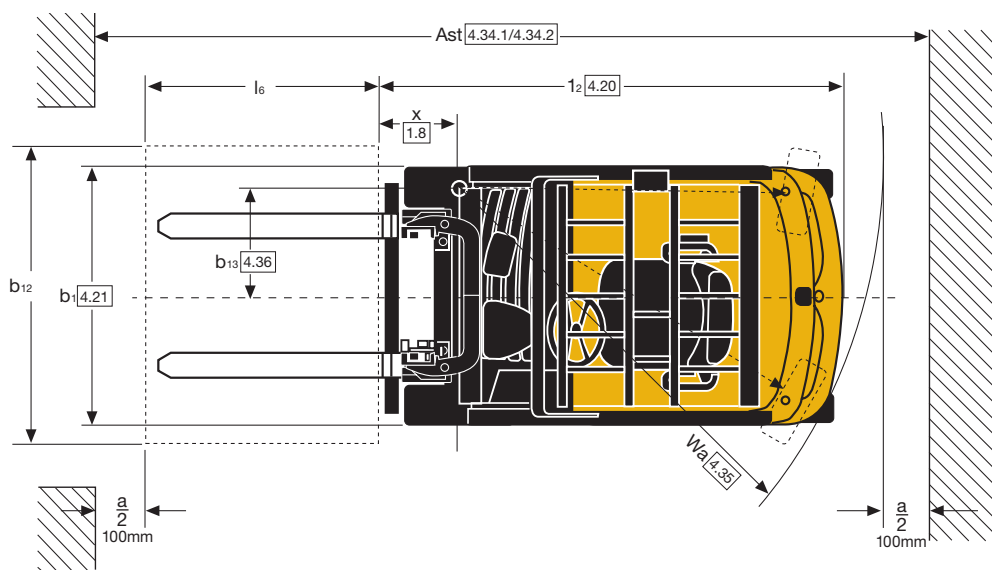
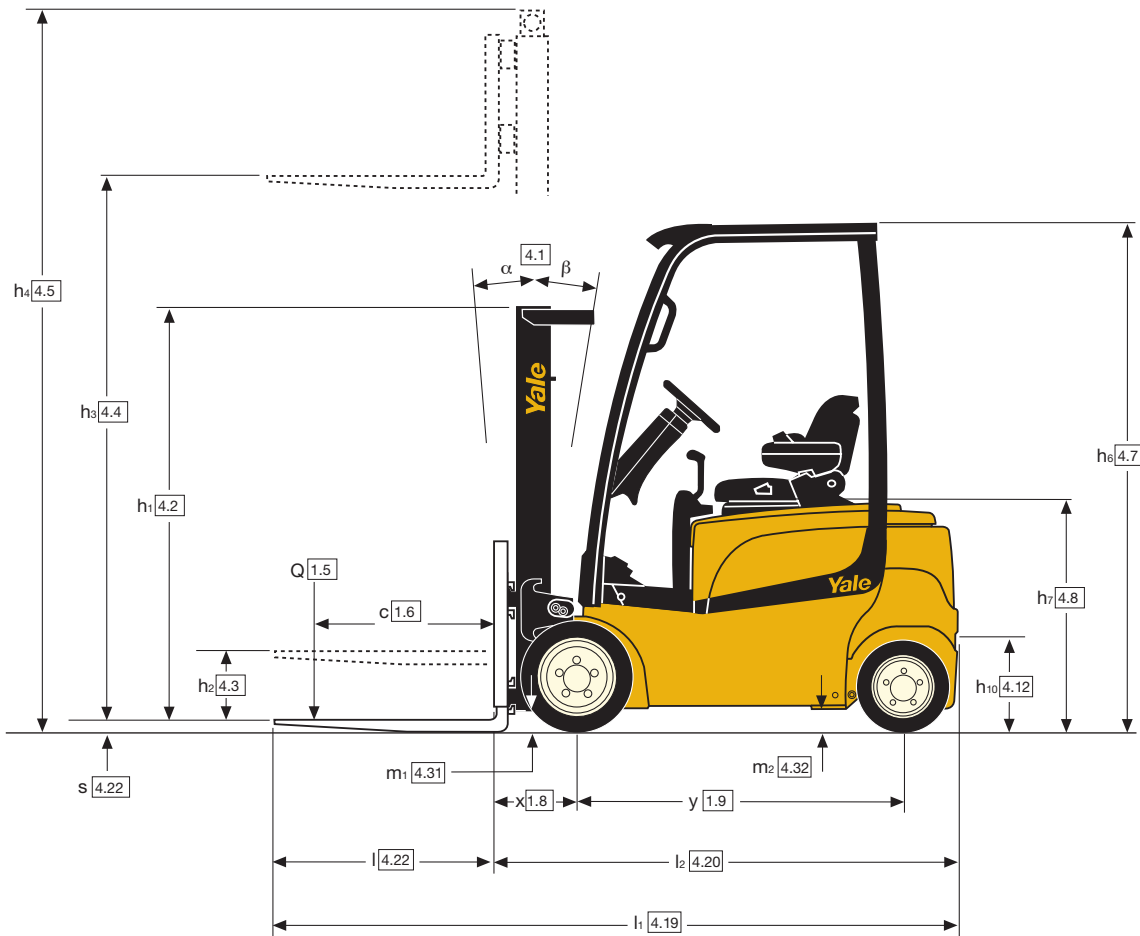

ERP16VF MWB mast details and capacity ratings (kg) - Superelastic tyres

Model							ERP16VF MWB					
Tyre size, front							18 x 7-8					
Overall width, front							1050mm					
Mast	h ₁ (mm)	h _{2+S} (mm)	h _{3+S} (mm)	h ₄ (mm)	Tilt		Forks			Integral sideshift		
					F	B	500	600	700	500	600	700
							Load centre kg)			Load centre kg)		
2 Stage LFL Clear View	2230	140	3360	3868	5	5	1600	1450	1350	1600	1430	1300
	2580	140	3860	4368	5	5	1600	1450	1340	1590	1430	1290
	2830	140	4360	4868	5	5	1580	1430	1330	1570	1410	1270
	3180	140	4860	5368	5	5	1490	1350	1250	1480	1320	1200
2 Stage LFL Hi-Vis	2180	140	3432	4006	5	5	1600	1450	1350	1580	1410	1280
	2530	140	3932	4506	5	5	1600	1450	1340	1570	1410	1270
	2780	140	4432	5006	5	5	1580	1430	1330	1550	1390	1260
	3130	140	4932	5506	5	5	1490	1350	1240	1450	1300	1180
2 Stage FFL Hi-Vis	2080	1505	3218	3728	5	5	1600	1450	1340	1570	1410	1270
	2330	1755	3718	4228	5	5	1600	1450	1340	1560	1400	1270
	2680	2105	4338	4847	5	5	1600	1450	1330	1550	1390	1260
3 Stage FFL Clear View	1980	1472	4300	4808	5	5	1600	1450	1340	1570	1410	1270
	2080	1572	4600	5108	5	5	1500	1400	1300	1480	1360	1230
	2180	1672	4900	5408	5	5	1350	1350	1250	1320	1310	1190
	2330	1822	5200*	5708	5	5	1220	1220	1190	1190	1190	1140
	2430	1922	5500*	6008	5	5	1090	1090	1090	1060	1060	1060
3 Stage FFL Hi-Vis	1930	1355	4300	4875	5	5	1600	1450	1340	1570	1410	1270
	2030	1455	4600	5175	5	5	1570	1420	1320	1540	1380	1250
	2130	1555	4900	5375	5	5	1460	1370	1270	1420	1330	1200
	2280	1705	5200*	5775	5	5	1320	1320	1220	1290	1270	1150
	2380	1805	5500*	6075	5	5	1190	1190	1160	1160	1160	1100

Note that the capacities are given in kilograms.

All ratings with DIN Battery.

All ratings with 1000mm forks and less load backrest.

* Tilt speed reduced to 1° per second by mechanical tilt speed restrictors for mast heights 5000mm and above.

ERP16VF LWB mast details and capacity ratings (kg) - Superelastic tyres

Model							ERP16VF LWB					
Tyre size, front							18 x 7-8					
Overall width, front							1050mm					
Mast	h ₁ (mm)	h _{2+S} (mm)	h _{3+S} (mm)	h ₄ (mm)	Tilt		Forks			Integral sideshift		
					F	B	500	600	700	500	600	700
							Load centre kg)			Load centre kg)		
2 Stage LFL Clear View	2230	140	3360	3868	5	5	1600	1450	1350	1600	1430	1300
	2580	140	3860	4368	5	5	1600	1450	1340	1590	1430	1290
	2830	140	4360	4868	5	5	1580	1430	1330	1570	1410	1270
	3180	140	4860	5368	5	5	1500	1360	1250	1480	1330	1200
2 Stage LFL Hi-Vis	2180	140	3432	4006	5	5	1600	1450	1350	1580	1410	1280
	2530	140	3932	4506	5	5	1600	1450	1340	1570	1410	1270
	2780	140	4432	5006	5	5	1580	1430	1330	1550	1390	1260
	3130	140	4932	5506	5	5	1500	1360	1250	1460	1310	1180
2 Stage FFL Hi-Vis	2080	1505	3218	3728	5	5	1600	1450	1340	1570	1410	1270
	2330	1755	3718	4228	5	5	1600	1450	1340	1560	1400	1270
	2680	2105	4338	4847	5	5	1600	1450	1330	1550	1390	1260
3 Stage FFL Clear View	1980	1472	4300	4808	5	5	1600	1450	1340	1570	1410	1270
	2080	1572	4600	5108	5	5	1510	1400	1300	1470	1360	1230
	2180	1672	4900	5408	5	5	1360	1360	1250	1320	1310	1190
	2330	1822	5200*	5708	5	5	1230	1230	1200	1190	1190	1140
	2430	1922	5500*	6008	5	5	1100	1100	1100	1060	1060	1060
3 Stage FFL Hi-Vis	1930	1355	4300	4875	5	5	1600	1450	1340	1570	1410	1270
	2030	1455	4600	5175	5	5	1570	1420	1320	1540	1380	1250
	2130	1555	4900	5375	5	5	1450	1380	1270	1430	1330	1210
	2280	1705	5200*	5775	5	5	1330	1320	1220	1290	1280	1160
	2380	1805	5500*	6075	5	5	1200	1200	1170	1160	1160	1110

Note that the capacities are given in kilograms.

All ratings with DIN Battery.

All ratings with 1000mm forks and less load backrest.

* Tilt speed reduced to 1° per second by mechanical tilt speed restrictors for mast heights 5000mm and above.

ERP18VF MWB mast details and capacity ratings (kg) - Superelastic tyres

Model							ERP18VF MWB					
Tyre size, front							200 / 50-10					
Overall width, front							1116mm					
Mast	h ₁ (mm)	h _{2+S} (mm)	h _{3+S} (mm)	h ₄ (mm)	Tilt		Forks			Integral sideshift		
					F	B	500	600	700	500	600	700
							Load centre kg)			Load centre kg)		
2 Stage LFL Hi-Vis	2180	140	3432	4006	5	5	1800	1600	1490	1740	1560	1420
	2530	140	3932	4506	5	5	1800	1600	1480	1740	1560	1410
	2780	140	4432	5006	5	5	1780	1580	1470	1720	1540	1390
	3130	140	4932	5506	5	5	1580	1500	1380	1540	1450	1310
2 Stage FFL Hi-Vis	2080	1505	3218	3728	5	5	1800	1600	1500	1750	1570	1420
	2330	1755	3718	4228	5	5	1800	1600	1490	1750	1560	1420
	2680	2105	4338	4847	5	5	1800	1600	1480	1740	1560	1410
3 Stage FFL Hi-Vis	1930	1355	4300	4875	5	5	1800	1600	1490	1740	1560	1410
	2030	1455	4600	5175	5	5	1770	1570	1460	1710	1530	1390
	2130	1555	4900	5375	5	5	1710	1520	1410	1650	1480	1340
	2280	1705	5200*	5775	5	5	1650	1470	1360	1590	1420	1290
	2380	1805	5500*	6075	5	5	1590	1410	1300	1520	1360	1230

Note that the capacities are given in kilograms.
All ratings with DIN Battery.
All ratings with 1000mm forks and less load backrest.

* Tilt speed reduced to 1° per second by mechanical tilt speed restrictors for mast heights 5000mm and above.

ERP18VF LWB mast details and capacity ratings (kg) - Superelastic tyres

Model							ERP18VF LWB					
Tyre size, front							200 / 50-10					
Overall width, front							1116mm					
Mast	h ₁ (mm)	h _{2+S} (mm)	h _{3+S} (mm)	h ₄ (mm)	Tilt		Forks			Integral sideshift		
					F	B	500	600	700	500	600	700
							Load centre kg)			Load centre kg)		
2 Stage LFL Hi-Vis	2180	140	3432	4006	5	5	1800	1600	1490	1740	1560	1420
	2530	140	3932	4506	5	5	1800	1600	1480	1740	1560	1410
	2780	140	4432	5006	5	5	1780	1580	1470	1720	1540	1390
	3130	140	4932	5506	5	5	1580	1500	1380	1540	1450	1310
2 Stage FFL Hi-Vis	2080	1505	3218	3728	5	5	1800	1600	1500	1750	1570	1420
	2330	1755	3718	4228	5	5	1800	1600	1490	1750	1560	1420
	2680	2105	4338	4847	5	5	1800	1600	1480	1740	1560	1410
3 Stage FFL Hi-Vis	1930	1355	4300	4875	5	5	1800	1600	1490	1740	1560	1410
	2030	1455	4600	5175	5	5	1770	1570	1460	1710	1530	1380
	2130	1555	4900	5375	5	5	1710	1520	1410	1650	1480	1340
	2280	1705	5200*	5775	5	5	1600	1470	1360	1580	1420	1290
	2380	1805	5500*	6075	5	5	1470	1410	1300	1440	1360	1230

Note that the capacities are given in kilograms.
All ratings with DIN Battery.
All ratings with 1000mm forks and less load backrest.

* Tilt speed reduced to 1° per second by mechanical tilt speed restrictors for mast heights 5000mm and above.

ERP20VF MWB mast details and capacity ratings (kg) - Superelastic tyres

Model							ERP20VF MWB					
Tyre size, front							200 / 50-10					
Overall width, front							1116mm					
Mast	h ₁ (mm)	h _{2+S} (mm)	h _{3+S} (mm)	h ₄ (mm)	Tilt		Forks			Integral sideshift		
					F	B	500	600	700	500	600	700
							Load centre kg)			Load centre kg)		
2 Stage LFL Hi-Vis	2180	140	3432	4006	5	5	2000	1800	1640	1920	1720	1560
	2530	140	3932	4506	5	5	2000	1800	1630	1910	1720	1550
	2780	140	4432	5006	5	5	1980	1780	1620	1900	1700	1540
	3130	140	4932	5506	5	5	1570	1570	1530	1520	1520	1460
2 Stage FFL Hi-Vis	2080	1505	3218	3728	5	5	2000	1800	1650	1930	1730	1570
	2330	1755	3718	4228	5	5	2000	1800	1640	1920	1720	1560
	2680	2105	4338	4847	5	5	2000	1800	1630	1910	1720	1550
3 Stage FFL Hi-Vis	1930	1355	4300	4875	5	5	2000	1800	1640	1910	1710	1550
	2030	1455	4600	5175	5	5	1880	1770	1610	1840	1690	1530
	2130	1555	4900	5375	5	5	1710	1710	1560	1690	1640	1480
	2280	1705	5200*	5775	5	5	1580	1570	1510	1540	1540	1430
	2380	1805	5500*	6075	5	5	1440	1440	1440	1410	1410	1380

Note that the capacities are given in kilograms.
All ratings with DIN Battery.
All ratings with 1000mm forks and less load backrest.

* Tilt speed reduced to 1° per second by mechanical tilt speed restrictors for mast heights 5000mm and above.

ERP20VF LWB mast details and capacity ratings (kg) - Superelastic tyres

Model							ERP20VF LWB					
Tyre size, front							200 / 50-10					
Overall width, front							1116mm					
Mast	h ₁ (mm)	h _{2+S} (mm)	h _{3+S} (mm)	h ₄ (mm)	Tilt		Forks			Integral sideshift		
					F	B	500	600	700	500	600	700
							Load centre kg)			Load centre kg)		
2 Stage LFL Hi-Vis	2180	140	3432	4006	5	5	2000	1800	1640	1920	1720	1560
	2530	140	3932	4506	5	5	2000	1800	1630	1910	1720	1550
	2780	140	4432	5006	5	5	1980	1780	1620	1890	1700	1540
	3130	140	4932	5506	5	5	1570	1570	1530	1520	1520	1450
2 Stage FFL Hi-Vis	2080	1505	3218	3728	5	5	2000	1800	1650	1930	1730	1570
	2330	1755	3718	4228	5	5	2000	1800	1640	1920	1720	1560
	2680	2105	4338	4847	5	5	2000	1800	1630	1910	1720	1550
3 Stage FFL Hi-Vis	1930	1355	4300	4875	5	5	2000	1800	1640	1910	1710	1550
	2030	1455	4600	5175	5	5	1960	1770	1610	1880	1690	1530
	2130	1555	4900	5375	5	5	1910	1710	1560	1770	1630	1480
	2280	1705	5200*	5775	5	5	1670	1660	1500	1640	1570	1420
	2380	1805	5500*	6075	5	5	1540	1530	1440	1500	1500	1370

Note that the capacities are given in kilograms.
All ratings with DIN Battery.
All ratings with 1000mm forks and less load backrest.

* Tilt speed reduced to 1° per second by mechanical tilt speed restrictors for mast heights 5000mm and above.

VDI 2198 - General Specifications

Distinguishing mark	1.1	Manufacturer (abbreviation)		Yale	Yale
	1.2	Manufacturer's type designation		ERP16VF (MWB)	ERP16VF (LWB)
	1.3	Drive: electric (battery or mains), diesel, petrol, fuel gas		Electric (battery)	Electric (battery)
	1.4	Operator type: hand, pedestrian, standing, seated, order-picker		Seated	Seated
	1.5	Rated capacity/rated load	Q (t)	1.6	1.6
	1.6	Load centre distance	c (mm)	500	500
	1.8	Load distance, centre of drive axle to fork	x (mm)	326	326
	1.9	Wheelbase	y (mm)	1431	1539
	Weights	2.1	Service weight ■	kg	3036
2.2		Axle loading, laden front/rear ■	kg	3986 / 650	3992 / 817
2.3		Axle loading, unladen front/rear ■	kg	1461 / 1575	1533 / 1676
Tyres/chassis	3.1	Tyres: P=pneumatic, C=cushion, SE=superelastic		SE	SE
	3.2	Tyre size, front		18 x 7-8	18 x 7-8
	3.3	Tyre size, rear		140 / 55-9	140 / 55-9
	3.5	Wheels, number front/rear (x = driven wheels)		2X / 2	2X / 2
	3.6	Tread, front	b ₁₀ (mm)	889	889
	3.7	Tread, rear	b ₁₁ (mm)	918	918
	Dimensions	4.1	Tilt of mast/fork carriage forward/backward	/ (°)	5 / 5
4.2		Height, mast lowered	h ₁ (mm)	2230	2230
4.3		Free lift ▼	h ₂ (mm)	100	100
4.4		Lift ▼	h ₃ (mm)	3320	3320
4.5		Height, mast extended +	h ₄ (mm)	3868	3868
4.7		Height of overhead guard (cabin) ○	h ₆ (mm)	2070	2070
4.7.1		Cab height (open cab)		2087	2087
4.8		Seat height relating to SIP/stand height ✕	h ₇ (mm)	1017	1017
4.12		Coupling height	h ₁₀ (mm)	360	360
4.19		Overall length	l ₁₁ (mm)	2980	3088
4.20		Length to face of forks	l ₂ (mm)	1980	2088
4.21		Overall width ^(B)	b ₁ /b ₂ (mm)	1050 ^(A)	1050 ^(A)
4.22		Fork dimensions ISO 2331	s/e/l (mm)	40 / 80 / 1000	40 / 80 / 1000
4.23		Fork carriage ISO 2328, class/type A, B		2A	2A
4.24		Fork carriage width E	b ₃ (mm)	907	907
4.31		Ground clearance, laden, below mast	m ₁ (mm)	70	70
4.32		Ground clearance at centre of wheelbase ^(C)	m ₂ (mm)	100	100
4.33		Load dimension b ₁₂ × l ₆ crossways	b ₁₂ × l ₆ (mm)	1000 x 1200	1000 x 1200
4.34		Aisle width predetermined load dimensions	A _{st} (mm)	3309	3417
4.34.1		Aisle width for pallets 1000 × 1200 crossways	A _{st} (mm)	3309	3417
4.34.2		Aisle width for pallets 800 × 1200 lengthways	A _{st} (mm)	3432	3540
4.35	Turning radius	W _a (mm)	1654	1762	
4.36	Internal turning radius	b ₁₃ (mm)	0	0	
4.41	90° intersecting aisle (With pallet W = 1200mm, L = 1000mm)	mm	1778	1824	
4.42	Step Height (from ground to running board) ^(B)	mm	526	526	
4.43	Step Height	mm	484	484	
Performance data	5.1	Travel speed, laden/unladen *	km/h	16 / 16	16 / 16
	5.1.1	Travel speed, laden/unladen, backwards	km/h	16 / 16	16 / 16
	5.2	Lift speed, laden/unladen	m/s	0.43 / 0.59	0.43 / 0.59
	5.3	Lowering speed, laden/unladen	m/s	0.50 / 0.47	0.50 / 0.47
	5.5	Drawbar pull, laden/unladen **	N	3406 / 3680	3406 / 3680
	5.6	Max. drawbar pull, laden/unladen ***	N	11415 / 11690	11415 / 11690
	5.7	Gradeability, laden/unladen ****	%	11 / 16	11 / 16
	5.8	Max. gradeability, laden/unladen ***	%	25 / 35	25 / 35
	5.9	Acceleration time, laden/unladen *	s	4.6 / 4.1	4.6 / 4.1
	5.10	Service brake		Hydraulic	Hydraulic
Electric-engine	6.1	Drive motor rating S2 60 min	kW	2x 5.0	2x 5.0
	6.2	Lift motor rating at S3 15%	kW	12.0	12.0
	6.3	Battery according to DIN 43531/35/36 A, B, C, no		DIN 43531-A	DIN 43531-A
	6.4	Battery voltage/nominal capacity K5	(V)/(ah)	48 / 625	48 / 750
	6.5	Battery weight ●	kg	813 / 899	962 / 1064
	6.6	Energy consumption according to VDI cycle □	kWh/h @Nr of Cycles	5.1	5.1
8.1	Type of drive unit		AC Induction	AC Induction	
Addition data	10.1	Operating pressure for attachments	bar	180	180
	10.2	Oil volume for attachments ◇	l/min	40	40
	10.3	Hydraulic oil tank, capacity	l	19	19
	10.7	Sound pressure level at the driver's seat LPAZ ★	dB(A)	69	69
	10.8	Towing coupling, type DIN	dB(A)	Pin	Pin

* Standard / Wide tread

** 60 minute rating

*** 5 minute rating

**** 30 minute rating

■ Max. battery.

▼ Bottom of forks.

✚ Without load backrest.

○ h₆ subject to +/- 5mm tolerance.

✕ Full suspension seat at midpoint of suspension travel. Standard hood specified. 1051mm with raised hood.

▶ Add 32mm with load backrest.

✔ HiP performance setting.

◇ Maximum flow set through dash display.

* HiP performance.

● Min./max.

□ With manual hydraulic controls; 155 bar with e-hydraulic controls.

^(A) Overall width 1116 mm with required

200/50-10 tyres fitted for masts 5000mm and over.

^(B) With vertical battery removal; add 34mm with horizontal removal.

Yale	Yale	Yale	Yale	1.1	Distinguishing mark
ERP18VF (MWB)	ERP18VF (LWB)	ERP20VF (MWB)	ERP20VF (LWB)	1.2	
Electric (battery)	Electric (battery)	Electric (battery)	Electric (battery)	1.3	
Seated	Seated	Seated	Seated	1.4	
1.8	1.8	2.0	2.0	1.5	
500	500	500	500	1.6	
321	321	321	321	1.8	
1431	1539	1539	1539	1.9	
3288	3282	3565	3386	2.1	
4435 / 653	4368 / 714	4892 / 673	4719 / 668	2.2	
1601 / 1687	1608 / 1674	1743 / 1822	1652 / 1734	2.3	
SE	SE	SE	SE	3.1	
200 / 50-10	200 / 50-10	200 / 50-10	200 / 50-10	3.2	
140 / 55-9	140 / 55-9	15 x 4.5-8	140 / 55-9	3.3	
2X / 2	2X / 2	2X / 2	2X / 2	3.5	
908	908	906	908	3.6	
918	918	918	918	3.7	
5 / 5	5 / 5	5 / 5	5 / 5	4.1	
2180	2180	2180	2180	4.2	
100	100	100	100	4.3	
3390	3390	3390	3390	4.4	
4006	4006	4006	4006	4.5	
2070	2070	2070	2070	4.7	
2087	2087	2087	2087	4.7.1	
1017	1017	1017	1017	4.8	
360	360	360	360	4.12	
2975	3083	2975	3083	4.19	
1975	2083	1975	2083	4.20	
1116	1116	1116	1116	4.21	
40 / 80 / 1000	40 / 80 / 1000	40 / 100 / 1000	40 / 100 / 1000	4.22	
2A	2A	2A	2A	4.23	
977	977	977	977	4.24	
70	70	70	70	4.31	
100	100	100	100	4.32	
1000 x 1200	1000 x 1200	1000 x 1200	1000 x 1200	4.33	
3305	3413	3305	3413	4.34	
3305	3413	3305	3413	4.34.1	
3427	3535	3427	3535	4.34.2	
1654	1762	1654	1762	4.35	
0	0	0	0	4.36	
1800	1846	1800	1846	4.41	
526	526	526	526	4.42	
484	484	484	484	4.43	
16 / 16	16 / 16	16 / 16	16 / 16	5.1	
16 / 16	16 / 16	16 / 16	16 / 16	5.1.1	
0.41 / 0.60	0.41 / 0.60	0.40 / 0.58	0.40 / 0.58	5.2	
0.46 / 0.40	0.46 / 0.40	0.47 / 0.40	0.47 / 0.40	5.3	
3337 / 3646	3337 / 3646	3260 / 3603	3294 / 3637	5.5	
11355 / 11664	11346 / 11655	11269 / 11612	11304 / 11647	5.6	
10 / 15	10 / 15	9 / 14	9 / 15	5.7	
23 / 35	23 / 36	31 / 34	22 / 36	5.8	
4.6 / 4.1	4.6 / 4.1	4.6 / 4.1	4.6 / 4.1	5.9	
Hydraulic	Hydraulic	Hydraulic	Hydraulic	5.10	
2x 5.0	2x 5.0	2x 5.0	2x 5.0	6.1	
12.0	12.0	12.0	12.0	6.2	
DIN 43531-A	DIN 43531-A	DIN 43531-A	DIN 43531-A	6.3	
48 / 625	48 / 750	48 / 625	48 / 750	6.4	
813 / 899	962 / 1064	813 / 899	962 / 1064	6.5	
5.3	5.4	7.8	5.6	6.6	
AC Induction	AC Induction	AC Induction	AC Induction	8.1	
180	180	180	180	10.1	
40	40	40	40	10.2	
19	19	19	19	10.3	
69	69	69	69	10.7	
Pin	Pin	Pin	Pin	10.8	

Distinguishing mark

Weights

Tyres/chassis

Dimensions

Performance data

Electric-engine

Addition data

© 90 mm with horizontal battery removal.

★ LPAZ, measured according to the test cycles and based on the weighting values contained in EN12053.

Spec sheet truck based on:

3360mm (Clear View) and 3430mm (Hi-Vis) to top of fork, 2 stage LFL mast with standard carriage and 1000mm forks, with HiP performance setting, DIN battery configuration.

VF series

Models: ERP 16VF MWB/LWB,
ERP 18VF MWB/LWB, ERP 20VF MWB/LWB



AC Technology

Yale AC technology Class H traction motors are suitable for the most arduous applications. Smooth forward and reverse directional changes providing seamless driving action. In the high-performance or 'HiP' setting, AC technology provides increased speed and acceleration, even when fully laden, and increased speed on grade. As well as improving performance, AC technology reduces maintenance and allows service intervals of 1000 hours for most components.

Brakes

The truck is equipped with automatic park brake and oil immersed brakes. Automatic YaleStop™ park brake: spring applied, electro magnetically released park brakes are mounted at the end of both motors. The park brake is automatically set by the control system, so that the brake is always set whenever the truck is not moving, and no traction has been requested. Moreover the park brake provides controllability on ramp applications.

Steering

E-steering eliminates the hydraulic steering lines from the steer column which is infinitely adjustable in a range of 26°. The E-steering also incorporates the synchronous steering function so the steer knob always returns to the home position which can be selected via the dash display. During cornering the speed of the drive motors is continuously adjusted independently by the traction controller ensuring smooth operation. The Yale VF features a state-of-the-art new customised steer-axle that has increased articulation of the steer wheels, allowing it to turn in smaller spaces than a conventional 4-wheel steer-axle.

Performance modes

Performance of the truck can be tailored via the enhanced overhead display, with 4 performance modes available to suit the requirements of the application or the preferences of the driver. For maximum speed and acceleration,

choose mode 4, or for more delicate manoeuvring and extended battery life, mode 1 is ideal.

Your service technician can alter the top speed and acceleration of mode 4, with modes 1, 2 and 3 being automatically adjusted as percentages of setting 4.

'eLo' and 'HiP' Settings

Yale VF trucks feature an 'eLo' energy saving setting (accessible via the dash display with service password), which provides exceptional energy efficient performance for when you require continuous operation over longer periods without recharging the battery. You can choose the 'HiP' high performance setting for higher top speeds and acceleration for the most demanding applications.

Improved ergonomics

The VF is designed for optimum operator comfort.

The operator is seated in an ergonomically designed position for maximum safety, comfort, visibility and ease of operation. The truck features a very low step height, generous floor and storage space, standard grab handle for ease of entry and standard reverse grab handle. The full suspension seat has 80mm of adjustment. A swivel seat option for a superior reverse driving position is available. Both the mini-lever module and the manual levers have an integrated direction switch. Clear footwell allows easy access from both sides.

Masts

A full range of Yale Hi-Vis™ 2 stage LFL and 2 and 3 stage FFL masts are available. Yale Hi-Vis™ masts are designed for maximum visibility, with widely spaced channels, lift chains and main lift cylinders. The new Yale Clear View™ Mast with class-leading visibility is offered on the 1.6 Ton capacity.

Battery

Choice of 2 battery sizes:
DIN and BS.

Choice of 2 wheelbases:

Depending on the capacity, there is a choice of Medium Wheelbase (MWB), and Long Wheelbase (LWB). The LWB versions provide extra battery space and longer shift life. MWB versions offer improved maneuverability and reduced stacking aisle dimensions. Battery discharge indicator and lift interrupt are standard on all trucks.

Battery Exchange

There are several different methods available to exchange the battery (should this be necessary), using either a crane, a 2nd fork lift tuck or the Yale purpose designed pallet truck. Battery exchange can be accomplished in under 3 minutes keeping truck downtime to a minimum.

Low lifetime costs

Lower maintenance costs as a result of less maintenance by oil immersed brakes, electric park brake, E-steering, CANbus and AC technology. Transmission is sealed for life, eliminating the need for service. LED light packages are offered as an option.

1000 hours service interval for most components.

Auto Regen Braking optimises the shift life of the battery and contributes to an increase in the life of parts.

Options



- AccuTouch™ mini-levers
- Foot directional control
- Lighting kits, including LED lights
- Reverse alarm
- Integrated sideshift
- DIN and BS battery
- Side battery extraction.

NACCO Materials Handling Limited
trading as **Yale Europe Materials Handling**
Centennial House, Frimley Business Park,
Frimley, Surrey GU16 7SG, United Kingdom.
Tel: +44 (0) 1276 538500 Fax: +44 (0) 1276 538559
www.yale-forklifts.eu

Country of Registration: England. Company Registration Number: 02636775



Safety. This truck conforms to the current EU requirements. Specification is subject to change without notice.

Yale, VERACITOR and  are registered trademarks. "PEOPLE, PRODUCTS, PRODUCTIVITY", PREMIER, Hi-Vis, and CSS are trademarks in the United States and certain other jurisdictions. MATERIALS HANDLING CENTRAL and MATERIAL HANDLING CENTRAL are Service Marks in the United States and certain other jurisdictions.  is a Registered Copyright.
© Yale Europe Materials Handling 2015. All rights reserved.

Truck shown with optional equipment

Printed in The United Kingdom (0515HG) EN
Publication part no. 258985624 Rev.07