

EC series

13000kg / 14000kg / 16000kg

Diesel Forklift Trucks



- Load Sensing Hydraulics, with highly efficient 'variable displacement' pumps
- Nominal lifting capacities including side shift carriage - Full capacity up to 6200mm lift height
- Transmissions, with smooth auto-shift system, also featuring protective lock-out on forward-reverse shifting and engine and transmission protection systems as standard
- 16t capacity truck with load centre of 1200mm available
- Fast lifting speeds, with a practical average of up to 0.40m/sec
- Excellent ergonomics.

Truck Dimensions

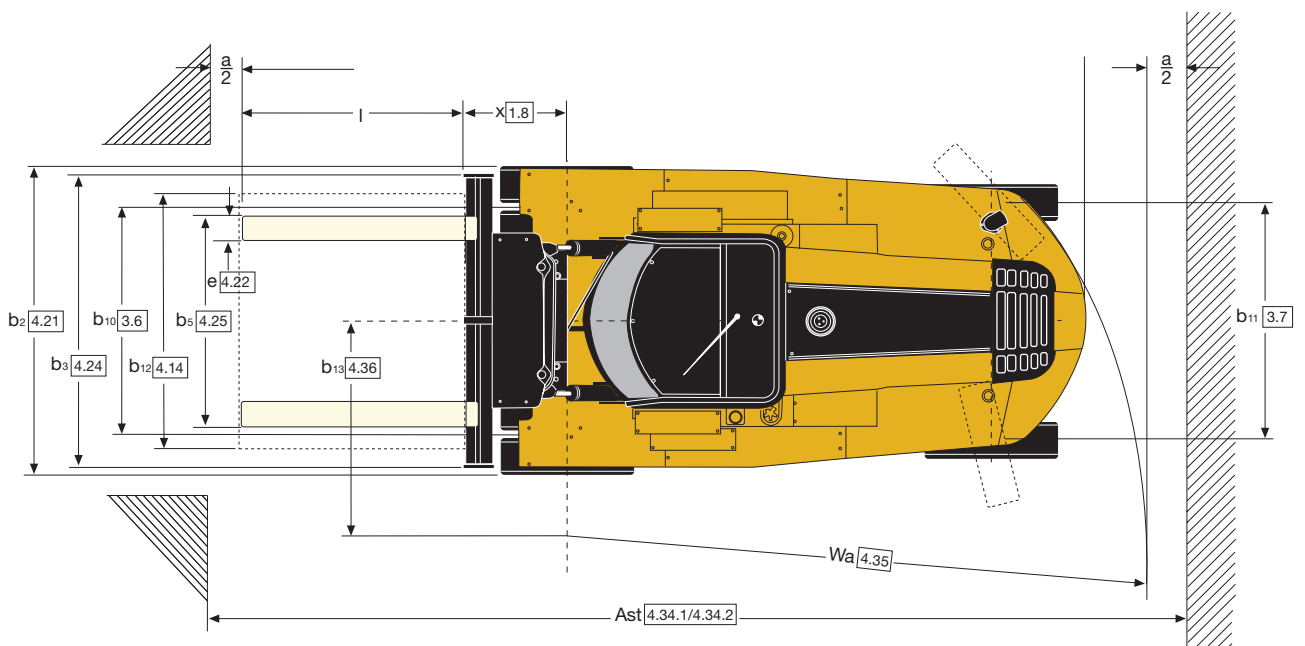
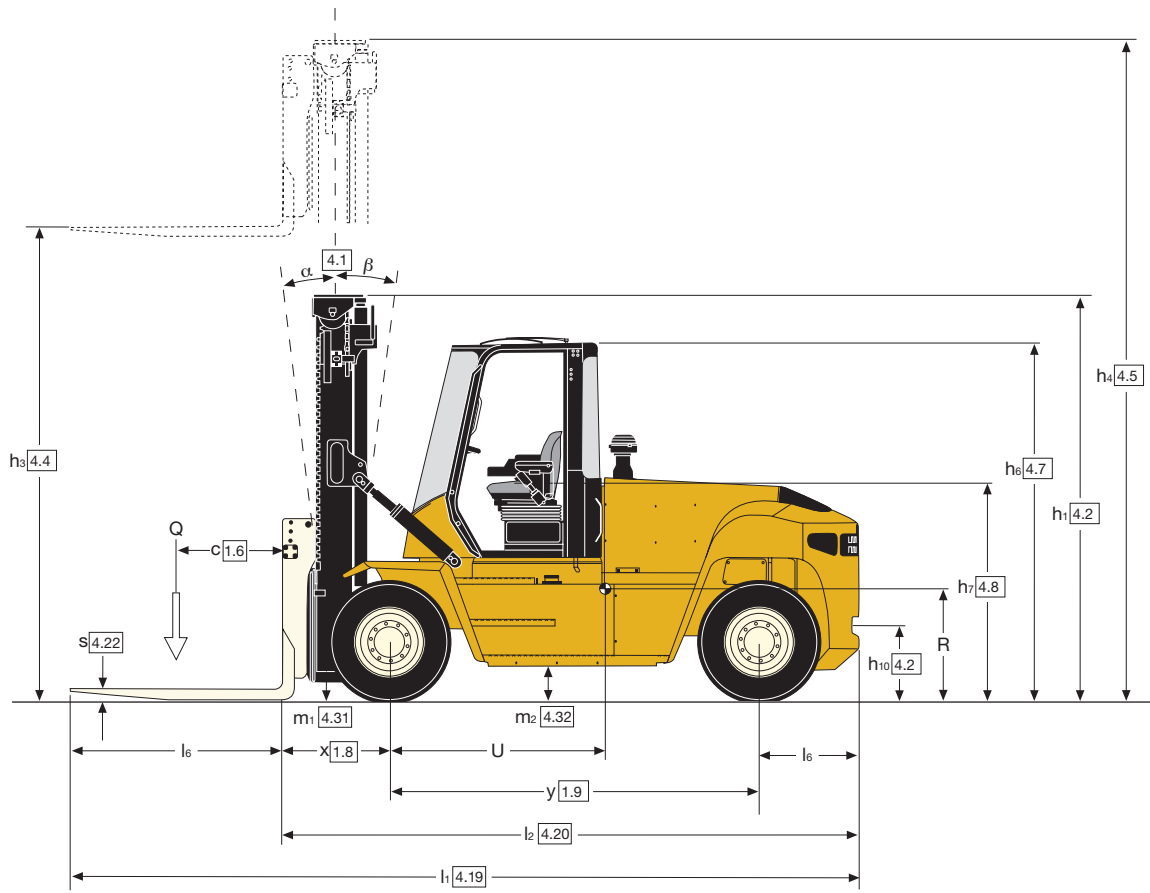

10-12T Mast - mast and capacity ratings (kg)

Lift height TOF ⁽¹⁾ h3+s (mm)	Overall lowered height h1 (mm)	h1 (mm) with 15° forward tilt	h1 (mm) with 27° forward tilt	Overall extended height h4 (mm)	GDP130EC, GDP140-EC, GDP160EC Rated capacity kg @ 600 mm load centre								
					Standard Pin Carriage (kg)			Sideshift Pin Carriage (kg)			DFSSFP QD ⁽²⁾ Carriage (kg)*		
					130EC	140EC	160EC	130EC	140EC	160EC	130EC	140EC	160EC
2750	3068	2985	2802	4398	13500	14500	16500	13400	14500	16400	13100	14400	16100
3000	3193	3105	2913	4648	13500	14500	16500	13400	14500	16400	13100	14400	16100
3250	3318	3226	3024	4898	13500	14500	16500	13400	14500	16400	13100	14400	16100
3500	3443	3347	3136	5148	13500	14500	16500	13400	14500	16400	13100	14400	16100
3750	3568	3468	3247	5398	13500	14500	16500	13400	14500	16400	13100	14400	16100
4000	3693	3588	3358	5648	13500	14500	16500	13400	14500	16400	13100	14400	16100
4500	3943	3830	3581	6148	13500	14500	16500	13400	14500	16400	13100	14400	16100
4750	4068	3951	3693	6398	13500	14500	16500	13400	14500	16400	13100	14400	16100
5000	4193	4071	3804	6648	13500	14500	16500	13400	14500	16400	13100	14360	16080
5500	4443	4313	4027	7148	13320	14320	16320	13180	14320	16160	Capacity will vary based on side shift and back-tilt.		
6000	4693	4554	4249	7648	13120	14140	16100	12960	14140	15920			
6250	4818	4675	4361	7898	13000	14060	15980	12840	14060	15800			
6500	4943	4796	4472	8148	12880	13960	15840	12720	13960	15680			
7000	5193	5037	4695	8648	12620	13740	15560	12460	13740	15400			

Capacity calculated with 1830mm forks.

Capacity calculated with radial tires, bias tyres will give a higher derate for DFSSFP carriage above 5000mm Load Height.

⁽¹⁾ TOF = Top of forks

⁽²⁾ DFSSFP QD = Dual Function Side Shifting Fork Positioner. Quick Detach.

All values are nominal values and they are subject to tolerances. For further information, please contact the manufacturer.

Yale products might be subject to change without notice.

Lift trucks illustrated may feature optional equipment.

Values may vary with alternative configurations.

Rated Load

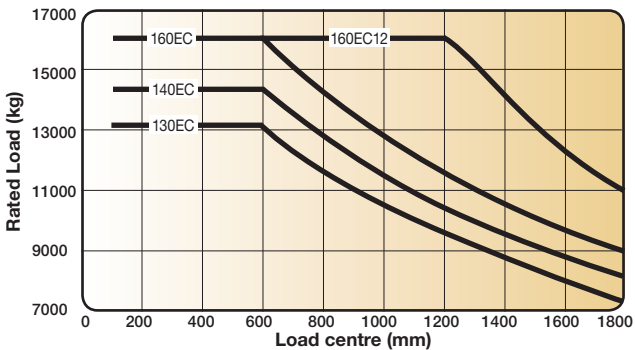

Mast range



GDP 160EC12 DFSSFP carriages

DFSSFP carriage 350 mm sideshift				
Dimensions	4.25	Width over forks (min / max) cylinders inner position	bs (mm)	555 1045
	4.25	Width over forks (min / max) cylinders outer position	bs (mm)	1875 2445
	4.30	Sideshift @ width over forks	b8/b5 (mm)	+/-98 2250
	4.30	Sideshift @ width over forks cylinders inner position	b8/b5 (mm)	+/-350 1745
	4.30	Sideshift @ width over forks cylinders outer position	b8/b5 (mm)	+/-350 1175
	DFSSFP carriage 468 mm sideshift			
4.25	Width over forks (min / max)	b5 (mm)	575 2445	
4.25	Sideshift @ width over forks	b8/b5 (mm)	+/-98 2250	
4.25	Sideshift @ width over forks	b8/b5 (mm)	+/-468 1510	

VDI 2198 – General Specifications

			Yale	Yale	Yale	Yale					
Distinguishing mark	1.1	Manufacturer (abbreviation)		Yale	Yale	Yale	Yale				
	1.2	Manufacturer's type designation		GDP 130EC	GDP 140EC	GDP 160EC	GDP 160EC12				
	1.3	Drive: electric (battery or mains), diesel, petrol, fuel gas		Diesel	Diesel	Diesel	Diesel				
	1.4	Operator type: hand, pedestrian, standing, seated, orderpicker		Seated	Seated	Seated	Seated				
	1.5	Rated capacity / rated load	Q (kg)	13500	14500	16500	16000				
	1.6	Load centre distance	c (mm)	600	600	600	1200				
	1.8	Load distance	x (mm)	889	889	889	973				
	1.9	Wheelbase	y (mm)	3300	3300	3300	3750				
	Weights	2.1	Service weight	kg	18414	19219	20019	23322			
2.2		Axle loading, laden front / rear	kg	29554 / 2359	30988 / 2731	33871 / 2648	36541 / 2781				
2.3		Axle loading, unladen front / rear	kg	9963 / 8451	9945 / 9274	9926 / 10093	11270 / 12052				
Tyres/chassis	3.1	Tyres: L=Pneumatic, V=solid, SE=Pneumatic Shape Solid		P	P	P	P				
	3.2	Tyres size, front		12.00-20 20PR	12.00-20 20PR	12.00-20 20PR	12.00-20 20PR				
	3.3	Tyres size, rear		12.00-20 20PR	12.00-20 20PR	12.00-20 20PR	12.00-20 20PR				
	3.5	Wheels, number front / rear (x = driven wheels)		4X / 2	4X / 2	4X / 2	4X / 2				
	3.6	Track width, front	b10 (mm)	1842	1842	1842	2218				
	3.7	Track width, rear	b11 (mm)	2000	2000	2000	1994				
	Dimensions	4.1	Mast tilt : forward / backwards	(°)	15 / 12	15 / 12	15 / 12	6 / 10			
4.2		Height of mast lowered (unloaded)	h1 (mm)	4193	4193	4193	3985				
4.4		Lift height (bottom of forks)	h3 (mm)	4910	4910	4910	4494				
4.5		Height of mast extended (unloaded)	h4 (mm)	6648	6648	6648	6232				
4.7		Height of overhead guard (open cab)	h6 (mm)	3053	3053	3053	3054				
4.7.1		Height of overhead guard (closed cab)	h6 (mm)	3089	3089	3089	3090				
4.7.2		Height of overhead guard (closed cab w/ airco)	h6 (mm)	3122	3122	3122	3123				
4.7.3		Height of overhead guard (closed cab w/ strobe light)	h6 (mm)	3221	3221	3221	3222				
4.7.4		Height of overhead guard (closed cab w/ work lights)	h6 (mm)	3280	3280	3280	3281				
4.7.5		Height of overhead guard (closed cab w/ airco & strobe light)	h6 (mm)	3295	3295	3295	3296				
4.8		Seat height (Seat Index Point, ISO 5353)	h7 (mm)	1818	1818	1818	1921				
4.12		Coupling height	h10 (mm)	717	717	717	713				
4.17		Overhang	l5 (mm)	809	809	809	791				
4.19		Overall length	l1 (mm)	6828	6828	6828	7954				
4.20		Length to face of forks	l2 (mm)	4998	4998	4998	5514				
4.21		Overall width truck	b2 (mm)	2541	2541	2541	2542				
4.22		Fork dimensions	s/e/l (mm)	90 / 200 / 1830	90 / 200 / 1830	90 / 200 / 1830	100 / 200 / 2440				
4.23		Carriage type		85mm standard pin type	85mm standard pin type	85mm standard pin type	Dual Function - Sideshift/Fork Positioning				
4.24		Carriage width	b3 (mm)	2496	2496	2496	2540				
4.25		Distance over fork arms, minimum / maximum	b5 (mm)	470 / 2420	470 / 2420	470 / 2420	555 / 1045				
4.31		Ground clearance, under mast with load	m1 (mm)	245	245	245	187				
4.32		Ground clearance, centre of wheelbase	m2 (mm)	341	341	341	341				
4.33		Load size	w x l (mm)	1200 / 1200	1200 / 1200	1200 / 1200	2400 / 2400				
4.33.1	Aisle width (a=10%)	Ast (mm)	7340	7340	7340	9430					
4.33.2	Aisle width (a=0)	Ast (mm)	6673	6673	6673	8573					
4.33.3	Aisle width (a=200)	Ast (mm)	6873	6873	6873	8773					
4.34	Load size	w x l (mm)	1200 / 800	1200 / 800	1200 / 800	-					
4.34.1	Aisle width (a=10%)	Ast (mm)	6900	6900	6900	-					
4.34.2	Aisle width (a=0)	Ast (mm)	6273	6273	6273	-					
4.34.3	Aisle width (a=200)	Ast (mm)	6473	6473	6473	-					
4.35	Turning radius (outer)	Wa (mm)	4584	4584	4584	5200					
4.36	Internal turning radius	b13 (mm)	1890	1890	1890	2026					
Performance data	5.1	Travel speed laden/unladen **	km/h	27.4 / 29.0	27.4 / 29.0	27.4 / 29.0	27.4 / 29.0	27.0 / 28.7	27.1 / 28.7		
	5.2	Lifting speed laden/unladen 111cc Stage III / 126cc Stage IV	m/s	0.36 / 0.40	0.41 / 0.46	0.36 / 0.40	0.41 / 0.46	0.36 / 0.40	0.41 / 0.46	0.34 / 0.44	0.39 / 0.44
	5.3	Lowering speed laden/unladen	m/s	0.50 / 0.48	0.50 / 0.48	0.50 / 0.48	0.50 / 0.48	0.50 / 0.48	0.50 / 0.48	0.54 / 0.45	0.54 / 0.45
	5.5	Drawbar pull laden/unladen @ 1.6 km/hour	kN	99 / 102	109 / 111	99 / 101	108 / 111	98 / 101	108 / 111	97 / 100	106 / 109
	5.6	Drawbar pull laden/unladen @ stall	kN	111 / 114	121 / 123	111 / 114	121 / 123	111 / 113	120 / 123	110 / 113	120 / 123
	5.7	Gradeability laden/unladen @ 1.6 km/hour	%	33 / 37	37 / 37	31 / 35	35 / 35	29 / 34	32 / 34	26 / 33	29 / 33
	5.8	Gradeability laden/unladen @ stall	%	38 / 37	42 / 37	36 / 35	39 / 35	32 / 34	36 / 34	30 / 33	33 / 33
Combustion-engine	7.1	Engine manufacturer / type	Cummins	QSB 6.7 Stage IIIA QSB 6.7 Stage IV	QSB 6.7 Stage IIIA QSB 6.7 Stage IV	QSB 6.7 Stage IIIA QSB 6.7 Stage IV	QSB 6.7 Stage IIIA QSB 6.7 Stage IV	QSB 6.7 Stage IIIA QSB 6.7 Stage IV	QSB 6.7 Stage IIIA QSB 6.7 Stage IV		
	7.2	Engine output according to ISO 1585 nominal	kW@rpm	116 @ 2300	122 @ 2300	116 @ 2300	122@2300	116 @ 2300	122@2300	116 @ 2300	122 @ 2300
	7.2.1	Engine output according to ISO 1585 max	kW@rpm	116 @ 2300	125 @ 2100	116 @ 2300	125 @ 2100	116 @ 2300	125 @ 2100	116 @ 2300	125 @ 2100
	7.2.2	Maximum engine torque	Nm@rpm	597 @ 1500	732 @ 1500	597 @ 1500	732 @ 1500	597 @ 1500	732 @ 1500	597 @ 1500	732 @ 1500
	7.3	Rated speed	rpm	2300	2300	2300	2300	2300	2300	2300	2300
	7.4	Number of cylinders / displacement	/ cm ³	6 / 6700	6 / 6700	6 / 6700	6 / 6700	6 / 6700	6 / 6700	6 / 6700	6 / 6700
	7.5	Fuel consumption in accordance to VDI	l/h	Call	Call	Call	Call	Call	Call	Call	Call
	7.8	Alternator	A	120	120	120	120	120	120	120	120
	7.10	Battery voltage/nominal capacity	V / Ah	24	102	24	102	24	102	24	102
	Drive train	8.1	Type of drive unit		Torque Converter	Torque Converter	Torque Converter	Torque Converter	Torque Converter	Torque Converter	
8.2		Transmission Manufacturer / Type		ZF / 3WG161	ZF / 3WG161	ZF / 3WG161	ZF / 3WG161	ZF / 3WG161	ZF / 3WG161		
8.3		Drive axle Manufacturer / Type		Kessler D81	Kessler D81	Kessler D81	Kessler D81	Kessler / D81	Kessler / D81		
8.4		Service brake		Oil immersed disc	Oil immersed disc	Oil immersed disc	Oil immersed disc	Oil-immersed / wet disc	Oil-immersed / wet disc		
8.5		Parking brake			Dry disc on drive axle			Dry disc on drive axle			
Addition data	10.1	Operating pressure for attachments	MPa	22.5	22.5	22.5	22.5	19.5	19.5		
	10.2	Oil volume for attachments	l/min	100	100	100	100	100	100		
	10.3	Hydraulic tank capacity	litres	140	140	140	140	140	140		
	10.4	Fuel tank capacity	litres	158	158	158	158	206	206		
	10.4.1	DEF tank capacity	litres	19	19	19	19	19	19		
	10.5	Steering design			Hydraulic power steering			Hydraulic power steering			
	10.6	Number of steering rotation		4.5 / TBD	4.5 / X	4.5 / X	4.5 / X	5.4	5.4		
	10.7	Sound pressure level at the driver's seat ***	dB (A)	72.8 / TBD	72.8 / X	72.8 / X	72.8 / X	75.0	74.0 / 73.0		
	10.7.1	Sound power level during the working cycle ***	dB (A)	108.5	108.5	108.5	108.5	109.5	108.1 / 105.1		
	10.8	Towing coupling, model / type	Pin		Pin		Pin	Pin	Pin		

* Based on Stage IV engine and Sideshift Apron Carriage.

** Travel speed laden/unladen limited at 25 km/h as factory default
*** Stage IV engine based on low mount exhaust.

All values are nominal values and they are subject to tolerances. For further information, please contact the manufacturer.
Yale products might be subject to change

without notice. Lift trucks illustrated may feature optional equipment. Values may vary with alternative configurations.

Masts and carriages

Yale's 2 stage masts with pin and hook type carriages on provides:

- Excellent visibility for the driver to the forks and load
- Optimised forward visibility
- Extended range of carriage options
- Easier manoeuvrability through reduced mast height and truck width
- Excellent durability and reliability
- Applies to 8-16t with load centres of 600mm only.



Standard fork positioning pin type carriage.

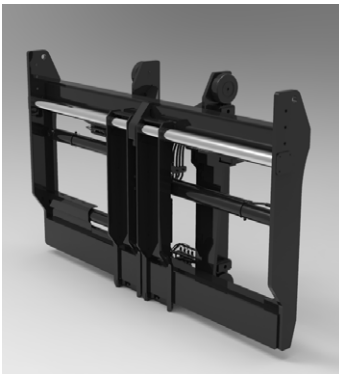

Apron-style sideshift and fork positioner pin type carriage.

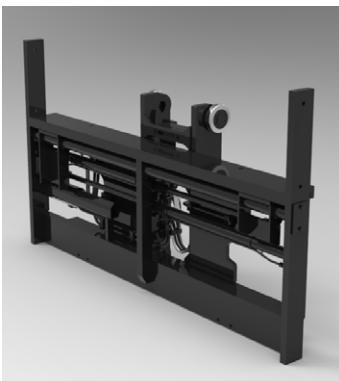

Apron-style sideshift and fork positioning pin type carriage for 3-stage mast only.

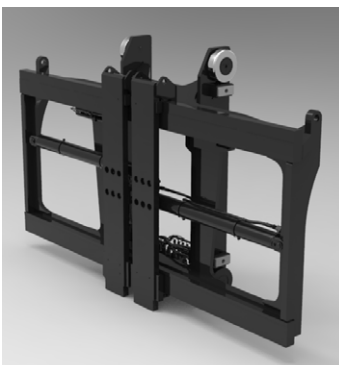

Dual function sideshift fork positioning carriage.

Standard equipment

- Cummins QSB 6.7 119kW / max. 122kW @ 2300rpm
 - 2200rpm Turbo Diesel Engine
 - Stage IV Compliant
 - ECO-eLo / HiP performance modes
 - Hibernate Idle
 - Hydraulically driven cooling fan
- ZFWG161 3 speed Hydrodynamic Transmission
- 2-Stage NFL Mast with maximum fork height of 5400mm
- Standard 75mm apron pin type carriage
- Wet Disc Brakes
- SAUER-DANFOSS dual piston pump 105 ccm (60 + 45ccm)
- Axle Tech PRC 425 Drive Axle
- Up to 6-way hydraulic controls with Levers and Switches combination
- Mast Tilt: 15° Forward / 12° Back
- Directional Control Lever
- Yale Operator Compartment with Integral Overhead Guard Featuring:
 - Seat-Side Hydraulic Control
 - Multifunction Display Panel
 - Interior Wide Angle Mirrors
 - Telescoping & Tilting Steering Column
 - Floor Mat
 - Isolated Mounting for Low Noise and Vibration
 - Handrails for Operator Entry and Exist
- Tyres – Drive and Steer
 - 10 x 20-16 pneumatic
- Steering Wheel with Spinner Knob
- Electronic Horn
- Mechanical, Full Suspension Vinyl or Cloth Seat with integrated adjustable armrest and seat belt
- Air Intake Cleaner with Rain Cap
- Low mount Exhaust
- Lockable Battery Disconnect Switch
- 24V Electrical System
- 120 Amp Alternator
- Manual Tilt Operator Compartment for Service Access
- Light Kit 6:
 - 4 Halogen Work Lights on Front Mast
 - 2 Rear Halogen Work Lights
 - 2 Headlights on Front Fender with Side, Stop, Tail, Indicator & Reverse Lights.
- Direction and position light with hazard function
- Non-Locking Fuel Cap
- Literature Package
 - Operator's Manual
- Warranty
 - 12 Months / 2000 Hours Manufacturer's Warranty

Optional equipment

- Masts
 - 2-Stage NFL Masts with maximum fork heights from 5400mm to 6700mm
 - 3-Stage FFL Masts with maximum fork heights from 4400mm to 7000mm
- Carriages
 - 2400mm Pin Type Carriage with Simultaneous and Independent Fork Positioner
 - 2400mm Pin Type Carriage with Simultaneous and Independent Fork Positioner
 - 2400mm Pin Type Side Shift Frame carriage
 - 2400mm Pin Type Integral Sideshift with Simultaneous Fork Positioner
 - 2400mm Pin Type Integral Sideshift with Simultaneous and Independent Fork Positioner
 - 2400mm QD Hook Type Dual Function Sideshift with Simultaneous and Independent Fork Positioner
 - 2400mm QD Hook Type Dual Function Sideshift with Simultaneous Fork Positioner with 2 Auxiliary Functions
- 5 Function Hydraulic Control Valve with 3 Levers, 2 Switches
- 6 Function Hydraulic Control Valve with 4 Levers, 2 Switches
- Hydraulic Control 5 function Joystick
- Mast Tilt:
 - 20.5° Forward / 7° Back
 - 5° Forward / 12° Back
- FDC pedal
- Tyres – Drive and Steer
 - 10.00-20 16PR TRELLEBORG pneumatics
 - 10.00-R20 Radial pneumatic
 - 10.00-20 Trelleborg Elite solids
- Steer Wheel Nut Protection
- Yale enclosed cab with or without Air Conditioning includes:
 - Seat-Side Hydraulic Control Levers
 - Multifunction Display Panel
 - Interior Wide Angle Mirrors
 - Telescoping & Tilting Steering Column
 - I - style Front screen Wiper
 - H - style Front screen Wiper
 - Floor Mat
 - 24-12V DC/DC Converter
 - Front (single blade), Top & Rear Wipers
 - Heater
 - Re-circulation Fan
- Enclosed Cab options
 - Top and rear sun shades
 - Temperature controller
 - Air conditioner, manual controlled

- Air conditioner, automatically controlled
- Reading light
- Trainer seat
- IT console for on-board computer
- Storage console
- Heated top window
- Engine start interlock
- Radio preparation, inclusive wire, two speakers and antenna
- Rain top (OHG only)
- Wire mesh protection guard on Top of cab
- External Mirror right and left

- Seats
 - Mechanical, Full Suspension High backrest Vinyl or Cloth Seat
 - Deluxe Air Suspended Full Suspension Cloth Seat
 - Heated Deluxe Air Suspended Full Suspension Cloth Seat
- 3-point seat belt for Deluxe Seat
- Powered Tilt Operator Compartment
- High mount Exhaust
- SAUER-DANFOSS dual piston pump 120 ccm
- Various Light Kits
- Battery master switch, lockable
- Amber strobe light - Ignition key and switch activated
- Self adjustable back up Alarm volume > 5dB(A) ambient
- Hydraulic Accumulator
- Lockable diesel fuel cap
- Lifting Eye Shackles
- Engine Block Heater-230V
- Traction Speed Limiter
- Automatic Engine Shutdown
- Hydraulic temperature protection
- Pressure compensated lowering
- Yale Vision Wireless Asset Management system
- Front and Rear Mud Flaps

Other options available through Special Engineering. Contact Yale for details.

EC series

Models: GDP 130EC, GDP 140EC, GDP 160EC, GDP 160EC12



The EC series offers superior traction, gradeability, drawbar pull, travel / lift speeds and excellent manoeuvrability, ideal for tough out-door applications.

Operator Compartment

The Operator Compartment is designed for maximum operator comfort and productivity.

Stage IV engines

Stage IV compliant diesel engines use Exhaust Gas Recirculation (EGR), a Diesel Oxygen Catalyst (DOC) and Selective Catalytic Reduction (SCR) technology to significantly reduce emission levels.

Cummins QSB 6.7L

The 6-cylinder engine delivers 125kW (168Hp) power and 732Nm of torque.

Transmissions

The automatic ZF 3WG161 transmission is fitted to all models with a heavy duty transmission oil pump to increase cooling oil flow to the clutches and torque converter.

A column-mounted lever or optional FDC pedal for direction changes give extremely smooth shifting with a forward-reverse lock-out function. Optimised shift points contribute to increased efficiency resulting in lower fuel consumption.

Power on Demand

Load-sensing hydraulics provide lifting power proportional to the load. Variable displacement pumps (VDP) ensure engine power is supplied only when required allowing more power for driving, increasing responsiveness and acceleration. Three pre-defined user modes can be selected allowing fine-tuning of the hydraulic controls.

Hydraulics

Load-sensing hydraulics (LSH) deliver faster lift and auxiliary hydraulic speeds for optimum productivity, especially with attachments. Oil is filtered at three locations to maintain high cleanliness for reliability.

Protection Systems

The engine protection system monitors coolant and air intake temperature and oil pressure. The transmission system monitors pressure, temperature and forward / reverse lockout on direction changes. The hydraulic system monitors low oil temperature.

Cooling System

The Quad-Cooler radiator contains separate cooling cores for engine,

transmission, hydraulics and charge air cooler designed to operate in a wide range of application temperatures.

Drive Axle

The drive axle has excellent sideways stability and long-term durability thanks to the fitment of strong end-reduction shafts and gears.

Steer Axle

The hydrostatic steer axle features a double-acting, single steering cylinder with adjustable end stops giving long lifespan and low maintenance. Load-sensing power steering ensures low-effort operation under all conditions

Chassis

A rugged unitised frame is designed for tough, demanding applications with excellent stability - the mast is directly mounted to it, handling loads to high lift heights.

Masts and Carriages

Enhanced mast and carriage arrangement delivers excellent visibility for the operator of the forks and load. *See pages 3 and 5 for further details on carriages.*

Electrics

Trucks use a 24 Volt system with 70A alternator and CAN bus connection. The LCD displays diagnostics for engine, transmission and electrical systems.

Lights

Mast mounted work lights, rear cab-mounted work lights, front marker lights, LED direction indicators, stop, tail and reverse lights.

Serviceability

Unobstructed access to the engine and key components via the sideways-tilting cab and 'gull-wing' doors. Service check points, centralised PC access and CAN bus connections help to reduce fault identification time. Longer service intervals increase uptime and reduce servicing costs. LSH oil change is up to 6000 hours, transmission oil change interval is 2000 hours.

Stage IV engine - additional features:

Auto Rev-Up:

Engine speed is automatically increased during lifting and tilting with the transmission is in neutral.

Drive Over Lift (DOL):

Priority is given to driving and fitting. Hydraulic performance is reduced while driving and performance is automatically increased when engine speed increases.

High performance Mode (HiP):

HiP mode maximises engine power and torque for hydraulic and drive functions.

Economy Mode (ECO-eLo):

ECO-eLo mode makes throttle reaction less aggressive, saving fuel, with reduced maximum engine speed.

Alternate idle mode:

Engine rpm is automatically reduced to stand-by mode if no functions are used for 30 seconds.

EC series

Models: GDP 130EC, GDP 140EC, GDP 160EC, GDP 160EC12





HYSTER-YALE UK LIMITED
trading as Yale Europe Materials Handling
Centennial House, Frimley Business Park,
Frimley, Surrey GU16 7SG, United Kingdom.

Tel: +44 (0) 1276 538500
Fax: +44 (0) 1276 538559

www.yale-forklifts.eu



Publication part no. 220990754 Rev.00 Printed in The Netherlands (0719HG) EN.
Safety: This truck conforms to the current EU requirements. Specification is subject to change without notice.

Yale, VERACITOR and  are registered trademarks. "PEOPLE, PRODUCTS, PRODUCTIVITY", PREMIER, Hi-Vis, and CSS are trademarks in the United States and certain other jurisdictions. MATERIALS HANDLING CENTRAL and MATERIAL HANDLING CENTRAL are Service Marks in the United States and certain other jurisdictions.  is a Registered Copyright.
© Yale Europe Materials Handling 2019. All rights reserved. Truck shown with optional equipment.
Country of Registration: England and Wales. Company Registration Number: 02636775