

EF series

16,000kg

Diesel Forklift Trucks



- 16t capacity truck with load centre of 1200mm
- Load Sensing Hydraulics, with highly efficient 'variable displacement' pumps
- Nominal lifting capacities including side shift carriage - Full capacity up to 6200mm lift height
- Transmissions, with smooth auto-shift system, also featuring protective lock-out on forward-reverse shifting and engine and transmission protection systems as standard
- Fast lifting speeds, with a practical average of up to 0.40m/sec
- Excellent ergonomics.

Truck Dimensions

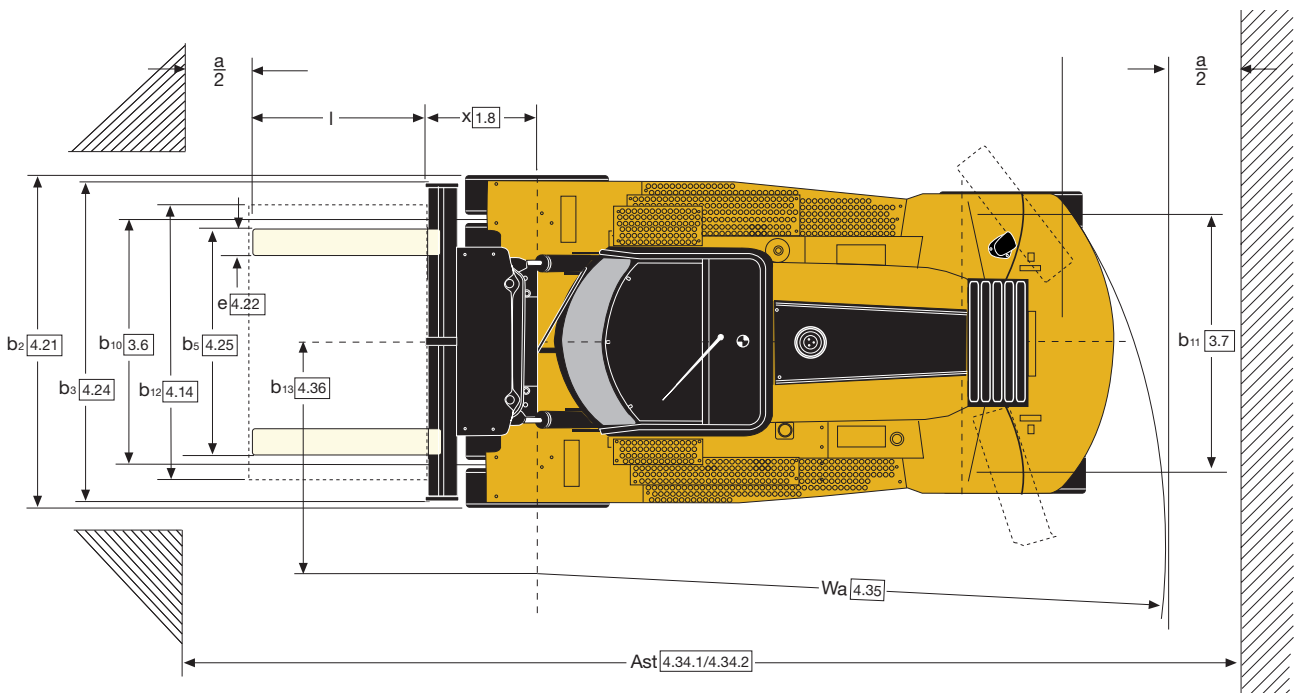
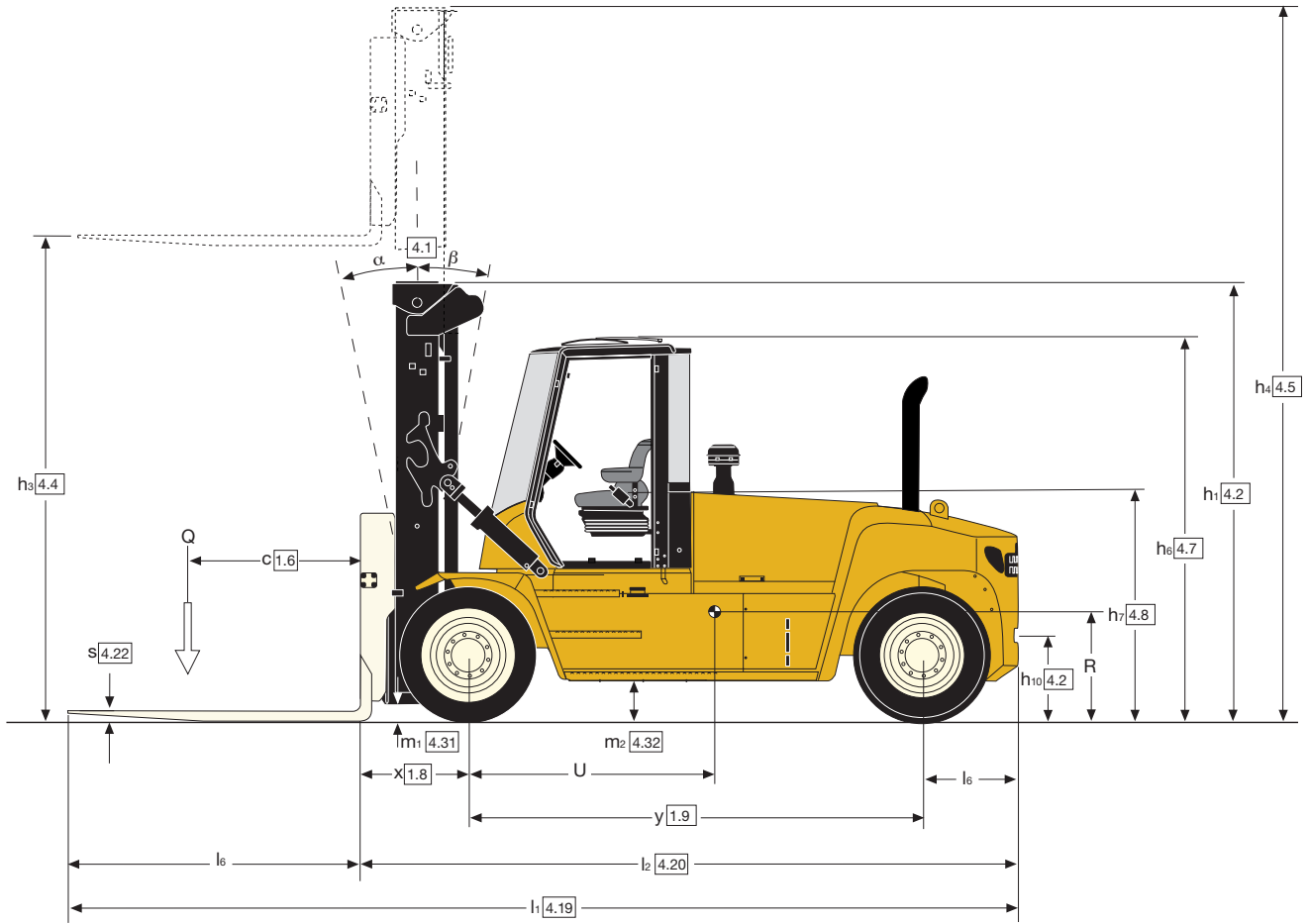

16T Mast - mast and capacity ratings (kg)

Lift height TOF h3+s (mm)	Overall lowered height h1 (mm)	Free Lift height h2 (mm)	Overall extended height h4 (mm)	GDP160EF
				Rated capacity kg @ 1200 mm load centre
3884	3680	0	5622	DFSSFP ⁽¹⁾ Carriage (kg) 16500
4494	3985	0	6232	16500
5306	4391	0	7044	16500
6119	4798	0	7858	15700

Masts: 2 stage 4494mm
Forks: 2440 x 100mm integrated forks

⁽¹⁾ DFSSFP = Dual Function Side Shifting Fork Positioner.

All values are nominal values and they are subject to tolerances. For further information, please contact the manufacturer.

Yale products might be subject to change without notice. Lift trucks illustrated may feature optional equipment. Values may vary with alternative configurations.

GDP 160EF12 DFSSFP carriages

DFSSFP carriage 350mm sideshift					
Dimensions	4.25	Width over forks (min. / max.) cylinders inner position	b5 (mm)	555 1045	
	4.25	Width over forks (min. / max.) cylinders outer position	b5 (mm)	1875 2445	
	4.30	Sideshift @ width over forks	b8/b5 (mm)	+/-98 2250	
	4.30	Sideshift @ width over forks cylinders inner position	b8/b5 (mm)	+/-350 1745	
	4.30	Sideshift @ width over forks cylinders outer position	b8/b5 (mm)	+/-350 1175	
	DFSSFP carriage 468mm sideshift				
	4.25	Width over forks (min. / max.)	b5 (mm)	575 2445	
	4.25	Sideshift @ width over forks	b8/b5 (mm)	+/-98 2250	
	4.25	Sideshift @ width over forks	b8/b5 (mm)	+/-468 1510	

Rated Load

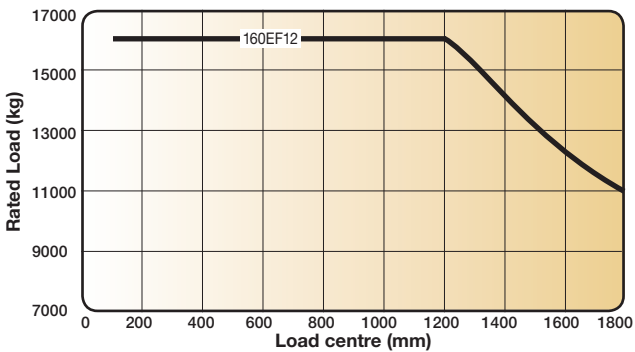

Mast range



VDI 2198 – General Specifications

Distinguishing mark	1.1	Manufacturer (abbreviation)		Yale	
	1.2	Manufacturer's type designation		GDP 160EF12	
	1.3	Drive: electric (battery or mains), diesel, petrol, fuel gas		Diesel	
	1.4	Operator type: hand, pedestrian, standing, seated, orderpicker		Seated	
	1.5	Rated capacity / rated load	Q (kg)	16000	
	1.6	Load centre distance	c (mm)	1200	
	1.8	Load distance	x (mm)	973	
	1.9	Wheelbase	y (mm)	3750	
	Weights	2.1	Service weight	kg	23337
2.2		Axle loading, laden front / rear	kg	36537 / 2799	
2.3		Axle loading, unladen front / rear	kg	11266 / 12071	
Tyres/chassis	3.1	Tyres: P = Pneumatic, V = solid, SE = Pneumatic Shape Solid		P	
	3.2	Tyres size, front		12.00 R20	
	3.3	Tyres size, rear		12.00 R20	
	3.5	Wheels, number front / rear (x = driven wheels)		4X / 2	
	3.6	Track width, front	b10 (mm)	2218	
	3.7	Track width, rear	b11 (mm)	1994	
	Dimensions	4.1	Mast tilt : forward / backwards	(°)α / β (°)	6 / 10
4.2		Height of mast lowered (unloaded)	h1 (mm)	3985	
4.4		Lift height (bottom of forks)	h3 (mm)	4494	
4.5		Height of mast extended (unloaded)	h4 (mm)	6232	
4.7		Height of overhead guard (open cab)	h6 (mm)	3083	
4.7.1		Height of overhead guard (closed cab)	h6 (mm)	3110	
4.7.2		Height of overhead guard (closed cab w/ airco)	h6 (mm)	3110	
4.7.3		Height of overhead guard (closed cab w/ strobe light)	h6 (mm)	3205	
4.7.4		Height of overhead guard (closed cab w/ work lights)	h6 (mm)	3259	
4.7.5		Height of overhead guard (closed cab w/ airco & strobe light)	h6 (mm)	3235	
4.8		Seat height (Seat Index Point, ISO 5353)	h7 (mm)	1903	
4.12		Coupling height	h10 (mm)	713	
4.17		Overhang	l5 (mm)	791	
4.19		Overall length	l1 (mm)	7954	
4.20		Length to face of forks	l2 (mm)	5514	
4.21		Overall width truck	b2 (mm)	2542	
4.22		Fork dimensions	s/e/l (mm)	100 / 200 / 2440	
4.23		Carriage type		Dual Function - Sideshift/Fork Positioning	
4.24		Carriage width	b3 (mm)	2540	
4.31		Ground clearance, under mast with load	m1 (mm)	187	
4.32		Ground clearance, centre of wheelbase	m2 (mm)	341	
4.33		Load size	w x l (mm)	2400 / 2400	
4.33.1		Aisle width (a=10%)	Ast (mm)	9430	
4.33.2		Aisle width (a=0)	Ast (mm)	8573	
4.33.3	Aisle width (a=200)	Ast (mm)	8773		
4.35	Turning radius (outer)	Wa (mm)	5200		
4.36	Internal turning radius	b13 (mm)	2026		
Performance data	5.1	Engine manufacturer / type		Cummins QSB 6.7 Stage IIIA	Cummins QSB 6.7 Stage IV
	5.1	Travel speed laden/unladen *	km/h	27.0 / 28.7	27.1 / 28.7
	5.2	Lifting speed laden/unladen	m/s	0.34 / 0.44	0.39 / 0.44
	5.2.1	Lifting speed with 70% load	m/s	0.37 / -	0.42 / -
	5.3	Lowering speed laden/unladen	m/s	0.54 / 0.45	0.54 / 0.45
	5.5	Drawbar pull laden/unladen @ 1.6 km/hour	kN	97 / 100	106 / 109
	5.6	Drawbar pull laden/unladen @ stall	kN	110 / 113	120 / 123
	5.7	Gradeability laden/unladen @ 1.6 km/hour	%	26 / 33	29 / 33
5.8	Gradeability laden/unladen @ stall	%	30 / 33	33 / 33	
Combustion-engine	7.1	Engine manufacturer / type		Cummins QSB 6.7 Stage IIIA	Cummins QSB 6.7 Stage IV
	7.2	Engine output according to ISO 1585 nominal	kW@rpm	116 @ 2300	122 @ 2300
	7.2.1	Engine output according to ISO 1585 max	kW@rpm	116 @ 2300	125 @ 2100
	7.2.2	Maximum engine torque	Nm@rpm	597 / 1500	732 @ 1500
	7.3	Rated speed	rpm	2300	2300
	7.4	Number of cylinders / displacement	/ cm ³	6 / 6700	6 / 6700
	7.5	Fuel consumption in accordance to VDI	l/h	Call	Call
	7.8	Alternator	A	120	120
7.10	Battery voltage/nominal capacity	V / Ah	24 / 102	24 / 102	
Drive train	8.1	Type of drive unit		Torque Converter	
	8.2	Transmission Manufacturer / Type		ZF / 3WG161	
	8.3	Drive axle Manufacturer / Type		Kessler / D81	
	8.4	Service brake		Oil-immersed / wet disc	
	8.5	Parking brake		Dry disc on drive axle	
Addition data	10.1	Operating pressure for attachments	MPa	19.5	
	10.2	Oil volume for attachments	ℓ/min	100	
	10.3	Hydraulic tank capacity	ℓ	140	
	10.4	Fuel tank capacity	ℓ	206	
	10.4.1	DEF tank capacity	ℓ	19	
	10.5	Steering design		Hydraulic power steering	
	10.6	Number of steering rotation		5.4	
	10.7	Sound pressure level at the driver's seat **	dB (A)	TBD	TBD
10.7.1	Sound power level during the working cycle **	dB (A)	109.5	105.1	
10.8	Towing coupling, model / type		Pin		

* Travel speed laden/unladen limited at 25km/h as factory default. low and high mount exhaust options. **For further information, please contact the manufacturer.**
 ** Stage IV engine measured with **All values are nominal values and they are subject to tolerances.**

Yale products might be subject to change without notice. optional equipment. Values may vary with alternative configurations.
Lift trucks illustrated may feature

Masts and carriages

Yale's 2 stage masts with pin and hook type carriages on provides:

- Excellent visibility for the driver to the forks and load
- Optimised forward visibility
- Extended range of carriage options
- Easier manoeuvrability through reduced mast height and truck width
- Excellent durability and reliability



Standard fork positioning pin type carriage.

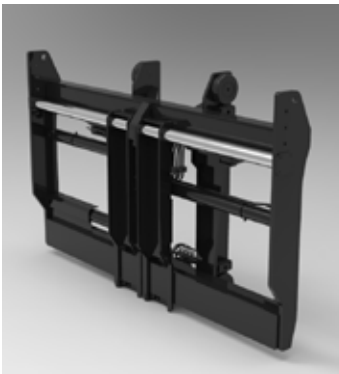

Apron-style sideshift and fork positioner pin type carriage.

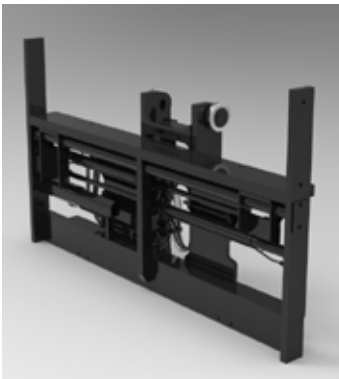

Apron-style sideshift and fork positioning pin type carriage for 3-stage mast only.



Dual function sideshift fork positioning carriage.

Standard equipment

- Cummins QSB 6.7 119kW / max. 122kW @ 2300rpm
 - Turbo Diesel Engine
 - Stage IV Compliant
 - ECO-eLo / HiP performance modes
 - Hibernate Idle
 - Hydraulically driven cooling fan
- ZFWG161 3 speed Hydrodynamic Transmission
- 2-Stage NFL Mast with maximum fork height of 5400mm
- Dual Function - Sideshift/Fork Positioning
- Wet Disc Brakes
- SAUER-DANFOSS dual piston pump 90ccm (45 + 45ccm)
- Kessler D81 Drive Axle
- Up to 6-way hydraulic controls with Levers and Switches combination
- Mast Tilt: 6° Forward / 10° Back
- Yale Operator Compartment with Integral Overhead Guard Featuring:
 - Seat-Side Hydraulic Control
 - Multifunction Display Panel
 - Interior Wide Angle Mirrors
 - Telescoping & Tilting Steering Column
 - Floor Mat
 - Isolated Mounting for Low Noise and Vibration
 - Handrails for Operator Entry and Exit
 - Front screen wiper (single blade), top and rear wipers
- Tyres – Drive and Steer
12.00 R20 pneumatic
- Steering Wheel with Spinner Knob
- Electronic Horn
- Amber strobe light - Ignition key
- Mechanical, Full Suspension Vinyl or Cloth Seat with integrated adjustable armrest and seat belt
- Air Intake Cleaner with Rain Cap
- Low mount Exhaust
- 24V Electrical System
- 120 Amp Alternator
- Manual Tilt Operator Compartment for Service Access
- Light Kit 6:
 - 4 Halogen Work Lights on Front Mast
 - 2 Rear Halogen Work Lights
 - 2 Headlights on Front Fender with Side, Stop, Tail, Indicator & Reverse Lights
- Direction and position LED light with hazard function
- Non-Locking Fuel Cap
- Literature Package
 - Operator's Manual
- Warranty
 - 24 Months / 4000 Hours Manufacturer's Warranty

Optional equipment

- **Masts**
 - 2-Stage NFL Masts with maximum fork heights from 5400mm to 6700mm
 - 3-Stage FFL Masts with maximum fork heights from 4400mm to 7000mm
- **Carriages**
 - 2400mm Pin Type Carriage with Simultaneous and Independent Fork Positioner
 - 2400mm Pin Type Carriage with Simultaneous and Independent Fork Positioner
 - 2400mm Pin Type Side Shift Frame carriage
 - 2400mm Pin Type Integral Sideshift with Simultaneous Fork Positioner
 - 2400mm Pin Type Integral Sideshift with Simultaneous and Independent Fork Positioner
 - 2400mm QD Hook Type Dual Function Sideshift with Simultaneous and Independent Fork Positioner
 - 2400mm QD Hook Type Dual Function Sideshift with Simultaneous Fork Positioner with 2 Auxiliary Functions
- **5 Function Hydraulic Control Valve with 3 Levers, 2 Switches**
- **6 Function Hydraulic Control Valve with 4 Levers, 2 Switches**
- **Hydraulic Control 5 function Joystick**
- **Mast Tilt:**
 - 20.5° Forward / 7° Back
 - 5° Forward / 12° Back
- **FDC pedal**
- **Tyres – Drive and Steer**
 - 10.00-20 Trelleborg radial tyres
 - 10.00-R20 Michelin XZM radial tyres
 - 10.00-20 pneumatic shaped solid tyres
- **Steer Wheel Nut Protection**
- **Yale enclosed cab with or without Air Conditioning includes:**
 - Mini-levers hydraulic control
 - 7" integrated performance display
 - Interior Wide Angle Mirrors
 - Telescoping & Tilting Steering Column
 - H-style front screen wiper
 - Floor Mat
 - 24-12V DC/DC Converter
 - Heater
 - Re-circulation Fan
- **Enclosed Cab options**
 - Top and rear sun shades
 - Temperature controller
 - Air conditioner, manual controlled
 - Air conditioner, automatically controlled
 - Reading light

- Trainer seat
- IT console for on-board computer
- Storage console
- Heated top window
- Engine start interlock
- Radio preparation, inclusive wire, two speakers and antenna
- Rain top (OHG only)
- Wire mesh protection guard on Top of cab
- External Mirror right and left
- **Seats**
 - Mechanical, Full Suspension High backrest Vinyl or Cloth Seat
 - Deluxe Air Suspended Full Suspension Cloth Seat
 - Heated Deluxe Air Suspended Full Suspension Cloth Seat
- **3-point seat belt for Deluxe Seat**
- **Powered Tilt Operator Compartment**
- **High mount Exhaust**
- **SAUER-DANFOSS dual piston pump 111 ccm**
- **Various Light Kits**
- **Battery master switch, lockable**
- **Amber strobe light - switch activated**
- **Self adjustable back up Alarm volume > 5dB(A) ambient**
- **Hydraulic Accumulator**
- **Lockable diesel fuel cap**
- **Lifting Eye Shackles**
- **Engine Block Heater - 230V and 240V**
- **Traction Speed Limiter**
- **Automatic Engine Shutdown**
- **Hydraulic temperature protection**
- **Pressure compensated lowering**
- **Yale Vision Wireless Asset Management system**
- **Front and Rear Mud Flaps**
- **Lockable Battery Disconnect Switch**
- **Directional Control Lever**

Other options available through Special Engineering. Contact Yale for details.

EF series

Models: GDP 160EF12

The EF series offers superior traction, gradeability, drawbar pull, travel / lift speeds and excellent manoeuvrability, ideal for tough out-door applications.

New Operator Cabin

The new Operator Cabin is designed for maximum operator comfort and productivity featuring a “cockpit-style” workplace with all truck information and controls at the operators’ fingertips.

Unique lateral seat sliding further improves the view on the work task.

Excellent all-round visibility and operator protection is ensured by the armoured glass top window, curved front- and rear window and toughened glass doors.

High-capacity HVAC (heating, ventilation and air conditioning) system, an ergonomic adjustable control arm includes a wrist cushion and mini-levers, or joystick option with all-day comfort from suspended seats.

Low noise levels enable operator to remain focussed during shifts.



Stage IV engines

Stage IV compliant diesel engines use Exhaust Gas Recirculation (EGR), a Diesel Oxygen Catalyst (DOC) and Selective Catalytic Reduction (SCR) technology to significantly reduce emission levels.

Cummins QSB 6.7L

The 6-cylinder engine delivers 125kW (168Hp) power and 732Nm of torque.

Transmissions

The automatic ZF 3WG161 transmission is fitted to all models with a heavy duty transmission oil pump to increase cooling oil flow to the clutches and torque converter.

A column-mounted lever or optional FDC pedal for direction changes give extremely smooth shifting with a forward-reverse lock-out function. Optimised shift points contribute to increased efficiency resulting in lower fuel consumption.

Power on Demand

Load-sensing hydraulics provide lifting power proportional to the load. Variable displacement pumps (VDP) ensure engine power is supplied only when required allowing more power for driving, increasing responsiveness and acceleration. Three pre-defined user modes can be selected allowing fine-tuning of the hydraulic controls.

Hydraulics

Load-sensing hydraulics (LSH) deliver faster lift and auxiliary hydraulic speeds for optimum productivity, especially with attachments. Oil is filtered at three locations to maintain high cleanliness for reliability.

Protection Systems

The engine protection system monitors coolant and air intake temperature and oil pressure. The transmission system monitors pressure, temperature and forward / reverse lockout on direction changes. The hydraulic system monitors low oil temperature.

Cooling System

The Quad-Cooler radiator contains separate cooling cores for engine, transmission, hydraulics and charge air cooler designed to operate in a wide range of application temperatures.

Drive Axle

The drive axle has excellent sideways stability and long-term durability thanks to the fitment of strong end-reduction shafts and gears.

Steer Axle

The hydrostatic steer axle features a double-acting, single steering cylinder with adjustable end stops giving long lifespan and low maintenance. Load-sensing power steering ensures low-effort operation under all conditions

Chassis

A rugged unitised frame is designed for tough, demanding applications with excellent stability - the mast is directly

mounted to it, handling loads to high lift heights.

Masts and Carriages

Enhanced mast and carriage arrangement delivers excellent visibility for the operator of the forks and load.

See pages 3 and 5 for further details on carriages.

Electrics

Trucks use a 24 Volt system with 70A alternator and CAN bus connection. The LCD displays diagnostics for engine, transmission and electrical systems.

Lights

Mast mounted work lights, rear cab-mounted work lights, front marker lights, LED direction indicators, stop, tail and reverse lights.

Serviceability

Unobstructed access to the engine and key components via the sideways-tilting cab and ‘gull-wing’ doors. Service check points, centralised PC access and CAN bus connections help to reduce fault identification time. Longer service intervals increase uptime and reduce servicing costs. LSH oil change is up to 6000 hours, transmission oil change interval is 2000 hours.

Stage IV engine - additional features:

Auto Rev-Up:

Engine speed is automatically increased during lifting and tilting with the transmission is in neutral.

Drive Over Lift (DOL):

Priority is given to driving and fitting. Hydraulic performance is reduced while driving and performance is automatically increased when engine speed increases.

High performance Mode (HiP):

HiP mode maximises engine power and torque for hydraulic and drive functions.

Economy Mode (ECO-eLo):

ECO-eLo mode makes throttle reaction less aggressive, saving fuel, with reduced maximum engine speed.

Alternate idle mode:

Engine rpm is automatically reduced to stand-by mode if no functions are used for 30 seconds.

EF series

Models: GDP 160EF12



Yale Europe Materials Handling

Centennial House, Frimley Business Park,
Frimley, Surrey GU16 7SG
United Kingdom



Tel: +44 (0) 1276 538500
Fax: +44 (0) 1276 538559

www.yale.com

Publication part no. 220990957 Rev.00 Printed in The Netherlands (0520HG) EN.
HYSTER-YALE UK LIMITED trading as Yale Europe Materials Handling.

Safety: This truck conforms to the current EU requirements.

Specification is subject to change without notice.

Yale, VERACTOR and  are registered trademarks. "PEOPLE, PRODUCTS, PRODUCTIVITY",
PREMIER, Hi-Vis, and CSS are trademarks in the United States and certain other jurisdictions.
MATERIALS HANDLING CENTRAL and MATERIAL HANDLING CENTRAL are Service Marks in
the United States and certain other jurisdictions.  is a Registered Copyright.

© Yale Europe Materials Handling 2020. All rights reserved. Truck shown with optional equipment.
Country of Registration: England and Wales. Company Registration Number: 02636775

