

DC series

8,000kg / 9,000kg / 10,000kg /
12,000kg

Diesel Forklift Trucks



- Load Sensing Hydraulics, with highly efficient 'variable displacement' pumps
- Nominal lifting capacities including side shift carriage - Full capacity up to 6200mm lift height
- Transmissions, with smooth auto-shift system, also featuring protective lock-out on forward-reverse shifting and engine and transmission protection systems as standard
- Fast lifting speeds, with a practical average of up to 0.40m/sec
- Excellent ergonomics

8-9T Mast - mast and capacity ratings (kg)

Lift height TOF ⁽¹⁾ h3+s (mm)	Overall lowered height h1 (mm)	h1 (mm) with 15° forward tilt	h1 (mm) with 27° forward tilt	Overall extended height h4 (mm)	GDP80DC, GDP90DC Rated capacity kg @ 600 mm load centre					
					Standard Pin Carriage (kg)		Sideshift Pin Carriage (kg)		DFSSFP QD ⁽²⁾ Carriage (kg)*	
					80DC	90DC	80DC	90DC	80DC	90DC
3250	3007	2924	2743	4594	8500	9500	8400	9400	8200	9200
3500	3132	3045	2855	4844	8500	9500	8400	9400	8200	9200
3750	3257	3166	2966	5094	8500	9500	8400	9400	8200	9200
4000	3382	3286	3077	5344	8500	9500	8400	9400	8200	9200
4500	3632	3528	3300	5844	8500	9500	8400	9400	8200	9200
4750	3757	3649	3412	6094	8500	9500	8400	9400	8200	9200
5000	3882	3769	3523	6344	8500	9500	8400	9400	8200	9200
5500	4132	4011	3746	6844	8320	9300	8200	9200	8,080	8720

Capacity calculated with 1220mm forks.

⁽¹⁾ TOF = Top of forks

⁽²⁾ DFSSFP QD = Dual Function Side Shifting Fork Positioner. Quick Detach

Capacity calculated with radial tyres, bias tyres will give a higher derate for DFSSFP carriage above 5000 mm Load Height

10-12T Mast - mast and capacity ratings (kg)

Lift height TOF ⁽¹⁾ h3+s (mm)	Overall lowered height h1 (mm)	h1 (mm) with 15° forward tilt	h1 (mm) with 27° forward tilt	Overall extended height h4 (mm)	GDP100, GDP120DC Rated capacity kg @ 600 mm load centre								
					Standard Pin Carriage (kg)			Sideshift Pin Carriage (kg)			DFSSFP QD ⁽²⁾ Carriage (kg)*		
					100DCS	100DC	120DC	100DCS	100DC	120DC	100DCS	100DC	120DC
2750	3007	2924	2743	4344	10500	10500	12500	10400	10400	12400	10100	10100	12100
3000	3132	3045	2855	4594	10500	10500	12500	10400	10400	12400	10100	10100	12100
3250	3257	3166	2966	4844	10500	10500	12500	10400	10400	12400	10100	10100	12100
3500	3382	3286	3077	5094	10500	10500	12500	10400	10400	12400	10100	10100	12100
3750	3507	3407	3189	5344	10500	10500	12500	10400	10400	12400	10100	10100	12100
4000	3632	3528	3300	5594	10500	10500	12500	10400	10400	12400	10100	10100	12100
4500	3882	3769	3523	6094	10500	10500	12500	10400	10400	12400	10100	10100	12100
4750	4007	3890	3634	6344	10500	10500	12500	10400	10400	12400	10100	10100	12100
5000	4132	4011	3746	6594	10500	10500	12500	10400	10400	12400	10100	10100	11100
5500	4382	4252	3968	7094	10320	10320	12320	10220	10200	12200			
6000	4632	4494	4191	7594	10140	10120	12100	10020	10000	11980			
6250	4757	4615	4303	7844	10020	10020	11980	9920	9900	11880			
6500	4882	4735	4414	8094	9920	9900	11880	9800	9800	11760			
7000	5132	4977	4637	8594	9700	9680	11000	9600	9560	10760			

Capacity calculated with 1220mm forks.

Capacity calculated with radial tyres, bias tyres will give a higher derate for DFSSFP carriage above 5000mm Load Height.

⁽¹⁾ TOF = Top of forks

⁽²⁾ DFSSFP QD = Dual Function Side Shifting Fork Positioner. Quick Detach.

All values are nominal values and they are subject to tolerances. For further information, please contact the manufacturer.

Yale products might be subject to change without notice.

Lift trucks illustrated may feature optional equipment.

Values may vary with alternative configurations.

Rated Load

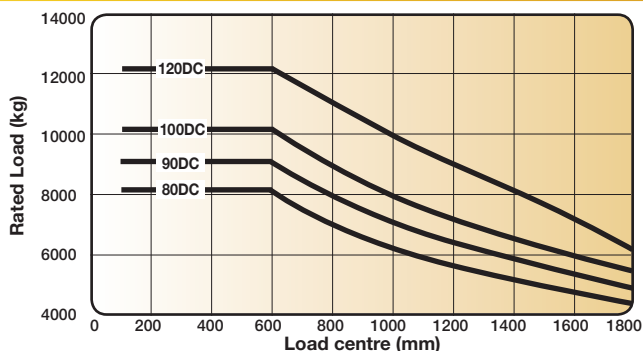

Mast range



VDI 2198 – General Specifications

			Yale	Yale	
Distinguishing mark	1.1	Manufacturer (abbreviation)		Yale	Yale
	1.2	Manufacturer's type designation		GDP 80DC	GDP 90DC
	1.3	Drive: electric (battery or mains), diesel, petrol, fuel gas		Diesel	Diesel
	1.4	Operator type: hand, pedestrian, standing, seated, orderpicker		Seated	Seated
	1.5	Rated capacity / rated load	Q (kg)	8500	9500
	1.6	Load centre distance	c (mm)	600	600
	1.8	Load distance	x (mm)	804	804
	1.9	Wheelbase	y (mm)	2700	2700
	Weights	2.1	Service weight *	kg	13040
2.2		Axle loading, laden front / rear	kg	19853 / 1688	21299 / 1836
2.3		Axle loading, unladen front / rear	kg	6933 / 6108	6859 / 6776
Tyres/chassis	3.1	Tyres: L=pneumatic, V=solid, SE=Pneumatic Shape Solid		P	P
	3.2	Tyres size, front		10.00-20 16PR	10.00-20 16PR
	3.3	Tyres size, rear		10.00-20 16PR	10.00-20 16PR
	3.5	Wheels, number front / rear (x = driven wheels)		4X / 2	4X / 2
	3.6	Track width, front	b10 (mm)	1842	1842
	3.7	Track width, rear	b11 (mm)	1930	1930
	Dimensions	4.1	Mast tilt : forward / backwards	(°)	15 / 12
4.2		Height of mast lowered (unloaded)	h1 (mm)	3882	3882
4.4		Lift height (bottom of forks)	h3 (mm)	4925	4925
4.5		Height of mast extended (unloaded)	h4 (mm)	6344	6344
4.7		Height of overhead guard (open cab)	h6 (mm)	3021	3021
4.7.1		Height of overhead guard (closed cab)	h6 (mm)	3057	3057
4.7.2		Height of overhead guard (closed cab w/ airco)	h6 (mm)	3090	3090
4.7.3		Height of overhead guard (closed cab w/ strobe light)	h6 (mm)	3189	3189
4.7.4		Height of overhead guard (closed cab w/ work lights)	h6 (mm)	3248	3248
4.7.5		Height of overhead guard (closed cab w/ airco & strobe light)	h6 (mm)	3263	3263
4.8		Seat height (Seat Index Point, ISO 5353)	h7 (mm)	1844	1844
4.12		Coupling height	h10 (mm)	649	649
4.17		Overhang	l5 (mm)	809	809
4.19		Overall length	l1 (mm)	5533	5533
4.20		Length to face of forks	l2 (mm)	4313	4313
4.21		Overall width truck	b2 (mm)	2464	2464
4.22		Fork dimensions	s/e/l (mm)	75 / 200 / 1220	75 / 200 / 1220
4.23		Carriage type		75 mm standard pin type	75 mm standard pin type
4.24		Carriage width	b3 (mm)	2396	2396
4.25		Distance over fork arms, minimum / maximum	b5 (mm)	470 / 2320	470 / 2320
4.31		Ground clearance, unladen, below mast	m1 (mm)	250	250
4.32		Ground clearance, centre of wheelbase	m2 (mm)	273	273
4.33		Load size	w x 1 (mm)	1200 / 1200	1200 / 1200
4.33.1		Aisle width (a=10%)	Ast (mm)	6523	6523
4.33.2	Aisle width (a=0)	Ast (mm)	5930	5930	
4.33.3	Aisle width (a=200)	Ast (mm)	6130	6130	
4.34	Load size	w x 1 (mm)	1200 / 800	1200 / 800	
4.34.1	Aisle width (a=10%)	Ast (mm)	6083	6083	
4.34.2	Aisle width (a=0)	Ast (mm)	5530	5530	
4.34.3	Aisle width (a=200)	Ast (mm)	5730	5730	
4.35	Turning radius (outer)	Wa (mm)	3926	3926	
4.36	Internal turning radius	b13 (mm)	1498	1498	
Performance data	5.1	Travel speed laden/unladen **	km/h	29.7 / 30.9	29.7 / 30.9
	5.2	Lifting speed laden/unladen 90cc Stage III/Stage IV	m/s	0.45 / 0.45	0.45 / 0.45
	5.2.1	Lifting speed laden/unladen 111cc Stage III/Stage IV	m/s	0.60 / 0.67	0.60 / 0.67
	5.3	Lowering speed laden/unladen	m/s	0.50 / 0.48	0.50 / 0.48
	5.5	Drawbar pull laden/unladen @ 1.6 km/hour	kN	96 / 97	101 / 102
	5.6	Drawbar pull laden/unladen @ stall	kN	106 / 108	106 / 107
	5.7	Gradeability laden/unladen @ 1.6 km/hour	%	51 / 33	51 / 33
	5.8	Gradeability laden/unladen @ stall	%	51 / 33	51 / 32
Combustion-engine	7.1	Engine manufacturer / type	Cummins	QSB 6.7 Stage IIIA	QSB 4.5 Stage IV
	7.2	Engine output according to ISO 1585 nominal	kW@rpm	116 @ 2300	119 @ 2300
	7.2.1	Engine output according to ISO 1585 max	kW@rpm	116 @ 2300	122 @ 2200
	7.2.2	Maximum engine torque	Nm@rpm	597 @ 1500	624 @ 1500
	7.3	Rated speed	rpm	2300	2300
	7.4	Number of cylinders / displacement	/ cm ³	6 / 6700	4 / 4500
	7.5	Fuel consumption in accordance to VDI	l/h	Call	Call
	7.8	Alternator	A	120	120
7.10	Battery voltage/nominal capacity	V / Ah	24	102	
Drive train	8.1	Type of drive unit		Torque Converter	Torque Converter
	8.2	Transmission Manufacturer / Type		ZF / 3WG161	ZF / 3WG161
	8.3	Drive axle Manufacturer / Type		Kessler D61	Kessler D61
	8.4	Service brake		Oil immersed disc	Oil immersed disc
	8.5	Parking brake		Dry disc on drive axle	Dry disc on drive axle
Addition data	10.1	Operating pressure for attachments	MPa	22.5	22.5
	10.2	Oil volume for attachments	l/min	100	100
	10.3	Hydraulic tank capacity	litres	135	135
	10.4	Fuel tank capacity	litres	104	104
	10.4.1	DEF tank capacity	litres	19	19
	10.5	Steering design		Hydraulic power steering	Hydraulic power steering
	10.6	Number of steering rotation		4.5	4.5
	10.7	Sound pressure level at the driver's seat ***	dB (A)	75.8 / 72.3	75.8 / 72.3
	10.7.1	Sound power level during the working cycle ***	dB (A)	108.5 / 106.5	108.5 / 106.5
	10.8	Towing coupling, model / type		Yes / Pin	Yes / Pin

* Based on Stage IV engine and Sideshift Frame Carriage

** Travel speed laden/unladen limited at 25 km/h as factory default

*** Stage IV engine based on low mount exhaust

All values are nominal values and they are subject to tolerances. For further information, please contact the manufacturer.

Yale products might be subject to change without notice
Lift trucks illustrated may feature optional equipment.
Values may vary with alternative configurations.

Yale	Yale	Yale		Manufacturer (abbreviation)	1.1		
GDP 100DCS	GDP 100DC	GDP 120DC		Manufacturer's type designation	1.2		
Diesel	Diesel	Diesel		Drive: electric (battery or mains), diesel, petrol, fuel gas	1.3		
Seated	Seated	Seated		Operator type: hand, pedestrian, standing, seated, orderpicker	1.4		
10500	10500	12500	Q (kg)	Rated capacity / rated load	1.5		
600	600	600	c (mm)	Load centre distance	1.6		
804	804	804	x (mm)	Load distance	1.8		
2700	2900	2900	y (mm)	Wheelbase	1.9		
14721	14335	15590	kg	Service weight *	2.1		
23201 / 2021	22966 / 1869	25792 / 2298	kg	Axle loading, laden front / rear	2.2		
7241 / 7481	7383 / 6952	7241 / 8350	kg	Axle loading, unladen front / rear	2.3		
P	P	P		Tyres: L=pneumatic, V=solid, SE=Pneumatic Shape Solid	3.1		
10.00-20 16PR	10.00-20 16PR	10.00-20 16PR		Tyres size, front	3.2		
10.00-20 16PR	10.00-20 16PR	10.00-20 16PR		Tyres size, rear	3.3		
4X / 2	4X / 2	4X / 2		Wheels, number front / rear (x = driven wheels)	3.5		
1842	1842	1842	b10 (mm)	Track width, front	3.6		
1930	1930	1930	b11 (mm)	Track width, rear	3.7		
15 / 12	15 / 12	15 / 12	(°)	Mast tilt : forward / backwards	4.1		
4132	4132	4132	h1 (mm)	Height of mast lowered (unloaded)	4.2		
4925	4925	4925	h3 (mm)	Lift height (bottom of forks)	4.4		
6594	6594	6594	h4 (mm)	Height of mast extended (unloaded)	4.5		
3021	3021	3021	h6 (mm)	Height of overhead guard (open cab)	4.7		
3057	3057	3057	h6 (mm)	Height of overhead guard (closed cab)	4.7.1		
3090	3090	3090	h6 (mm)	Height of overhead guard (closed cab w/ airco)	4.7.2		
3189	3189	3189	h6 (mm)	Height of overhead guard (closed cab w/ strobe light)	4.7.3		
3248	3248	3248	h6 (mm)	Height of overhead guard (closed cab w/ work lights)	4.7.4		
3263	3263	3263	h6 (mm)	Height of overhead guard (closed cab w/ airco & strobe light)	4.7.5		
1844	1844	1844	h7 (mm)	Seat height (Seat Index Point, ISO 5353)	4.8		
649	649	649	h10 (mm)	Coupling height	4.12		
809	809	809	l5 (mm)	Overhang	4.17		
5533	5733	5733	l1 (mm)	Overall length	4.19		
4313	4513	4513	l2 (mm)	Length to face of forks	4.20		
2464	2464	2464	b2 (mm)	Overall width truck	4.21		
75 / 200 / 1220	75 / 200 / 1220	75 / 200 / 1220	s/e/l (mm)	Fork dimensions	4.22		
75 mm standard pin type	75 mm standard pin type	75 mm standard pin type		Carriage type	4.23		
2396	2396	2396	b3 (mm)	Carriage width	4.24		
470 / 2320	470 / 2320	470 / 2320	b5 (mm)	Distance over fork arms, minimum / maximum	4.25		
250	250	250	m1 (mm)	Ground clearance, unladen, below mast	4.31		
273	273	273	m2 (mm)	Ground clearance, centre of wheelbase	4.32		
1200 / 1200	1200 / 1200	1200 / 1200	w x 1 (mm)	Load size	4.33		
6523	6727	6727	Ast (mm)	Aisle width (a=10%)	4.33.1		
5930	6115	6115	Ast (mm)	Aisle width (a=0)	4.33.2		
6130	6315	6315	Ast (mm)	Aisle width (a=200)	4.33.3		
1200 / 800	1200 / 800	1200 / 800	w x 1 (mm)	Load size	4.34		
6083	6287	6287	Ast (mm)	Aisle width (a=10%)	4.34.1		
5530	5715	5715	Ast (mm)	Aisle width (a=0)	4.34.2		
5730	5915	5915	Ast (mm)	Aisle width (a=200)	4.34.3		
3926	4111	4111	Wa (mm)	Turning radius (outer)	4.35		
1498	1545	1545	b13 (mm)	Internal turning radius	4.36		
29.7 / 30.9	29.7 / 30.9	29.7 / 30.9	29.7 / 30.9	29.7 / 30.9	km/h	5.1	
0.40 / 0.40	0.40 / 0.40	0.40 / 0.40	0.40 / 0.40	0.40 / 0.40	m/s	5.2	
0.47 / 0.54	0.50 / 0.54	0.47 / 0.54	0.50 / 0.54	0.47 / 0.54	m/s	5.2.1	
0.50 / 0.48	0.50 / 0.48	0.50 / 0.48	0.50 / 0.48	0.50 / 0.48	m/s	5.3	
95 / 97	100 / 102	95 / 97	100 / 102	95 / 97	kN	5.5	
105 / 107	112 / 114	105 / 107	112 / 114	105 / 107	111 / 113	kN	5.6
42 / 31	44 / 31	42 / 33	45 / 33	37 / 36	39 / 36	%	5.7
47 / 31	51 / 31	48 / 33	52 / 33	41 / 36	44 / 36	%	5.8
QSB 6.7 Stage IIIA	QSB 4.5 Stage IV	QSB 6.7 Stage IIIA	QSB 4.5 Stage IV	QSB 6.7 Stage IIIA	QSB 4.5 Stage IV	Cummins	7.1
16 @ 2300	119 @ 2300	16 @ 2300	119 @ 2300	116 @ 2300	119 @ 2300	kW@rpm	7.2
116 @ 2300	122 @ 2200	116 @ 2300	122 @ 2200	116 @ 2300	122 @ 2200	kW@rpm	7.2.1
597 @ 1500	624 @ 1500	597 @ 1500	624 @ 1500	597 @ 1500	624 @ 1500	Nm@rpm	7.2.2
2300	2300	2300	2300	2300	2300	rpm	7.3
6 / 6700	4 / 4500	6 / 6700	4 / 4500	6 / 6700	4 / 4500	/ cm ³	7.4
Call	Call	Call	Call	Call	Call	l/h	7.5
120	120	120	120	120	120	A	7.8
24	102	24	102	24	102	V / Ah	7.10
Torque Converter	Torque Converter	Torque Converter					8.1
ZF / 3WG161	ZF / 3WG161	ZF / 3WG161					8.2
Kessler D61	Kessler D61	Kessler D61					8.3
Oil immersed disc	Oil immersed disc	Oil immersed disc					8.4
Dry disc on drive axle	Dry disc on drive axle	Dry disc on drive axle					8.5
22.5	22.5	22.5	22.5	22.5	22.5	MPa	10.1
100	100	100	100	100	100	l/min	10.2
135	135	135	135	135	135	litres	10.3
104	137	104	137	104	137	litres	10.4
19	19	19	19	19	19	litres	10.4.1
Hydraulic power steering	Hydraulic power steering	Hydraulic power steering					10.5
4.5	4.5	4.5	4.5	4.5	4.5		10.6
75.8 / 72.3	75.8 / 72.3	75.8 / 72.3	75.8 / 72.3	75.8 / 72.3	75.8 / 72.3	dB (A)	10.7
108.5 / 106.5	108.5 / 106.5	108.5 / 106.5	108.5 / 106.5	108.5 / 106.5	108.5 / 106.5	dB (A)	10.7.1
Yes / Pin	Yes / Pin	Yes / Pin					10.8

Distinguishing mark

Weights

Tyres/chassis

Dimensions

Performance data

Combustion-engine

Drive Train

Addition data

Masts and carriages

Yale's 2 stage masts with pin and hook type carriages on provides:

- Excellent visibility for the driver to the forks and load
- Optimised forward visibility
- Extended range of carriage options
- Easier manoeuvrability through reduced mast height and truck width
- Excellent durability and reliability



Standard fork positioning pin type carriage

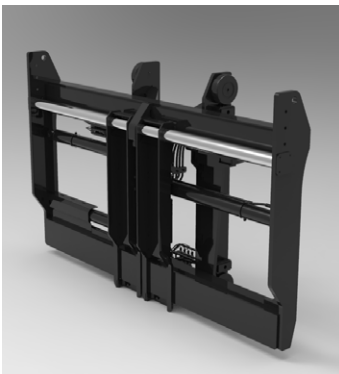

Apron-style sideshift and fork positioner pin type carriage.

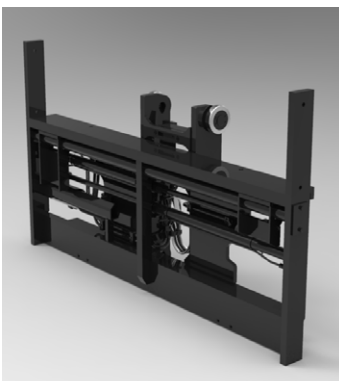

Apron-style sideshift and fork positioning pin type carriage for 3-stage mast only.

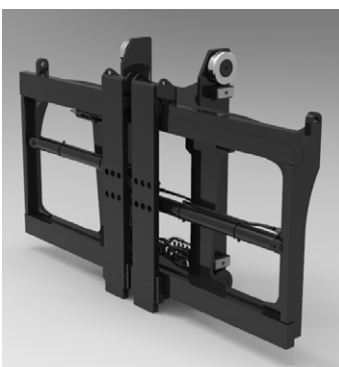

Dual function sideshift fork positioning carriage.

Standard equipment

- Cummins QSB 4.5 119kW / max 122kW @ 2300rpm
 - 2200rpm Turbo Diesel Engine
 - Stage IV Compliant
 - ECO-eLo / HiP performance modes
 - Hibernate Idle
 - Hydraulically driven cooling fan
- ZFWG161 3 speed Hydrodynamic Transmission
- 2-Stage NFL Mast with maximum fork height of 7000mm
- Standard 75mm apron pin type carriage
- Wet Disc Brakes
- SAUER-DANFOSS dual piston pump 105ccm (60 + 45ccm)
- Axle Tech PRC 425 Drive Axle
- Up to 6-way hydraulic controls with Levers and Switches combination
- Mast Tilt: 15° Forward / 12° Back
- Directional Control Lever
- Yale Operator Compartment with Integral Overhead Guard Featuring:
 - Seat-Side Hydraulic Control
 - Multifunction Display Panel
 - Interior Wide Angle Mirrors
 - Telescoping & Tilting Steering Column
 - Floor Mat
 - Isolated Mounting for Low Noise and Vibration
 - Handrails for Operator Entry and Exist
- Tyres – Drive and Steer
 - 10 x 20-16 pneumatic
- Steering Wheel with Spinner Knob
- Electronic Horn
- Mechanical, Full Suspension Vinyl or Cloth Seat with integrated adjustable armrest and seat belt
- Air Intake Cleaner with Rain Cap
- Low mount Exhaust
- Lockable Battery Disconnect Switch
- 24V Electrical System
- 120Amp Alternator
- Manual Tilt Operator Compartment for Service Access
- Light Kit 6:
 - 4 Halogen Work Lights on Front Mast
 - 2 Rear Halogen Work Lights
 - 2 Headlights on Front Fender with Side, Stop, Tail, Indicator & Reverse Lights.
- Direction and position light with hazard function
- Non-Locking Fuel Cap
- Literature Package
 - Operator's Manual
- Warranty
 - 12 Months / 2000 Hours Manufacturer's Warranty

Optional equipment

● Masts

- 2-Stage NFL Masts with maximum fork heights from 3250mm to 7000mm
- 3-Stage FFL Masts with maximum fork heights from 5500mm to 7000mm

● Carriages

- 2400mm Pin Type Carriage with Simultaneous and Independent Fork Positioner
- 2400mm Pin Type Carriage with Simultaneous and Independent Fork Positioner
- 2400mm Pin Type Side Shift Frame carriage
- 2400mm Pin Type Integral Sideshift with Simultaneous Fork Positioner
- 2400mm Pin Type Integral Sideshift with Simultaneous and Independent Fork Positioner
- 2400mm QD Hook Type Dual Function Sideshift with Simultaneous and Independent Fork Positioner
- 2400mm QD Hook Type Dual Function Sideshift with Simultaneous Fork Positioner with 2 Auxiliary Functions

● 5 Function Hydraulic Control Valve with 3 Levers, 2 Switches

● 6 Function Hydraulic Control Valve with 4 Levers, 2 Switches

● Hydraulic Control 5 function Joystick

● Mast Tilt:

- 20.5° Forward / 7° Back
- 5° Forward / 12° Back

● FDC pedal

● Tyres – Drive and Steer

- 10.00-20 16PR TRELLEBORG pneumatics
- 10.00-R20 Radial pneumatic
- 10.00-20 Trelleborg Elite solids

● Steer Wheel Nut Protection

● Yale enclosed cab with or without Air Conditioning includes:

- Seat-Side Hydraulic Control Levers
- Multifunction Display Panel
- Interior Wide Angle Mirrors
- Telescoping & Tilting Steering Column
- I - style Front screen Wiper
- H - style Front screen Wiper
- Floor Mat
- 24-12V DC/DC Converter
- Front (single blade), Top & Rear Wipers
- Heater
- Re-circulation Fan

● Enclosed Cab options

- Top and rear sun shades
- Temperature controller
- Air conditioner, manual controlled

- Air conditioner, automatically controlled

- Reading light
- Trainer seat
- IT console for on-board computer
- Storage console
- Heated top window
- Engine start interlock
- Radio preparation, inclusive wire, two speakers and antenna
- Rain top (OHG only)
- Wire mesh protection guard on Top of cab
- External Mirror right and left

● Seats

- Mechanical, Full Suspension High backrest Vinyl or Cloth Seat
- Deluxe Air Suspended Full Suspension Cloth Seat
- Heated Deluxe Air Suspended Full Suspension Cloth Seat

● 3-point seat belt for Deluxe Seat

● Powered Tilt Operator Compartment

● High mount Exhaust

● SAUER-DANFOSS dual piston pump 120 ccm

● Various Light Kits

● Battery master switch, lockable

● Amber strobe light - Ignition key and switch activated

● Self adjustable back up Alarm volume > 5dB(A) ambient

● Hydraulic Accumulator

● Lockable diesel fuel cap

● Lifting Eye Shackles

● Engine Block Heater-230V

● Traction Speed Limiter

● Automatic Engine Shutdown

● Hydraulic temperature protection

● Pressure compensated lowering

● Yale Vision Wireless Asset Management system

● Front and Rear Mud Flaps

Other options available through Special Products Engineering Development (SPED). Contact Yale for details.

DC series

Models: GDP 80DC, GDP 90DC, GDP 100DC, GDP 120DC



The DC series offers superior traction, gradeability, drawbar pull, travel / lift speeds and excellent manoeuvrability, ideal for tough out-door applications.

Operator Compartment

The Operator Compartment is designed for maximum operator comfort and productivity.

Stage IV engines

Stage IV compliant diesel engines use Exhaust Gas Recirculation (EGR), a Diesel Oxygen Catalyst (DOC) and Selective Catalytic Reduction (SCR) technology to significantly reduce emission levels.

Cummins QSB 4.5L

The 4-cylinder engine delivers maximum power and torque at low revs, offering extra durability for long periods of peak power operation.

Cummins QSB 6.7L

The 6-cylinder engine delivers 125kW (168Hp) power and 732Nm of torque.

Transmissions

The automatic ZF 3WG161 transmission, fitted to all models with a heavy duty transmission oil pump to increase cooling oil flow to the clutches and torque converter.

A column-mounted lever or optional FDC pedal for direction changes give extremely smooth shifting with a forward-reverse lock-out function. Optimised shift points contribute to increased efficiency resulting in lower fuel consumption.

Power on Demand

Load-sensing hydraulics provide lifting power proportional to the load. Variable displacement pumps (VDP) ensure engine power is supplied only when required allowing more power for driving, increasing responsiveness and acceleration. Three pre-defined user modes can be selected allowing fine-tuning of the hydraulic controls.

Hydraulics

Load-sensing hydraulics (LSH) deliver faster lift and auxiliary hydraulic speeds for optimum productivity, especially with

attachments. Oil is filtered at three locations to maintain high cleanliness for reliability.

Protection Systems

The engine protection system monitors coolant and air intake temperature and oil pressure. The transmission system monitors pressure, temperature and forward / reverse lockout on direction changes. The hydraulic system monitors low oil temperature.

Cooling System

The Quad-Cooler radiator contains separate cooling cores for engine, transmission, hydraulics and charge air cooler designed to operate in a wide range of application temperatures.

Drive Axle

The drive axle has excellent sideways stability and long-term durability thanks to the fitment of strong end-reduction shafts and gears.

Steer Axle

The hydrostatic steer axle features a double-acting, single steering cylinder with adjustable end stops giving long lifespan and low maintenance. Load-sensing power steering ensures low-effort operation under all conditions

Chassis

A rugged unitised frame is designed for tough, demanding applications with excellent stability - the mast is directly mounted to it, handling loads to high lift heights

Masts and Carriage

Enhanced mast and carriage arrangement delivers excellent visibility for the operator of the forks and load. *See page 6 for further details on carriages.*

Brakes

Oil-immersed brakes contribute to increased productivity and reduced ownership costs. The parking brake is a dry disc brake on the drive axle.

Electrics

Trucks use a 24 Volt system with 70A alternator and CANbus connection.

The LCD displays diagnostics for engine, transmission and electrical systems.

Lights

Mast mounted work lights, rear cab-mounted work lights, front marker lights, LED direction indicators, stop, tail and reverse lights.

Serviceability

Unobstructed access to the engine and key components via the sideways-tilting cab and 'gull-wing' doors. Service check points, centralised PC access and CANbus connections help to reduce fault identification time. Longer service intervals increase uptime and reduce servicing costs. LSH oil change is up to 6000 hours, transmission oil change interval is 2000 hours.

Stage IV engine - additional features:

Auto Rev-Up:

Engine speed is automatically increased during lifting and tilting with the transmission is in neutral.

Drive Over Lift (DOL):

Priority is given to driving and fitting. Hydraulic performance is reduced while driving and performance is automatically increased when engine speed increases.

High performance Mode (HiP):

HiP mode maximises engine power and torque for hydraulic and drive functions.

Economy Mode (ECO-eLo):

ECO-eLo mode makes throttle reaction less aggressive, saving fuel, with reduced maximum engine speed.

Alternate idle mode:

Engine rpm is automatically reduced to stand-by mode if no functions are used for 30 seconds.

HYSTER-YALE UK LIMITED

trading as **Yale Europe Materials Handling**
Centennial House, Frimley Business Park,
Frimley, Surrey GU16 7SG, United Kingdom.

Tel: +44 (0) 1276 538500



Fax: +44 (0) 1276 538559

www.yale-forklifts.eu



Publication part no. 220990738 Rev.00 Printed in The Netherlands (0719HG) EN.

Safety: This truck conforms to the current EU requirements. Specification is subject to change without notice.

Yale, VERACTOR and  are registered trademarks. "PEOPLE, PRODUCTS, PRODUCTIVITY", PREMIER, Hi-Vis, and CSS are trademarks in the United States and certain other jurisdictions. MATERIALS HANDLING CENTRAL and MATERIAL HANDLING CENTRAL are Service Marks in the United States and certain other jurisdictions.  is a Registered Copyright.
©Yale Europe Materials Handling 2019. All rights reserved. Truck shown with optional equipment.
Country of Registration: England and Wales. Company Registration Number: 02636775