

VX series

LP Gas Forklift Trucks

2,000kg / 2,500kg / 3,000kg / 3,500kg

- New high Visibility Masts and optional Side Shifting Fork Positioner
- Intellix[™] Vehicle Management System with CANbus technology
- 3 application matched transmissions, including the World's best hydrodynamic transmission - the Yale Techtronix[™]
- Oil immersed brakes
- AccuTouch[™] minilevers and manual levers
- Superelastic and pneumatic radial tyres



Truck Dimensions

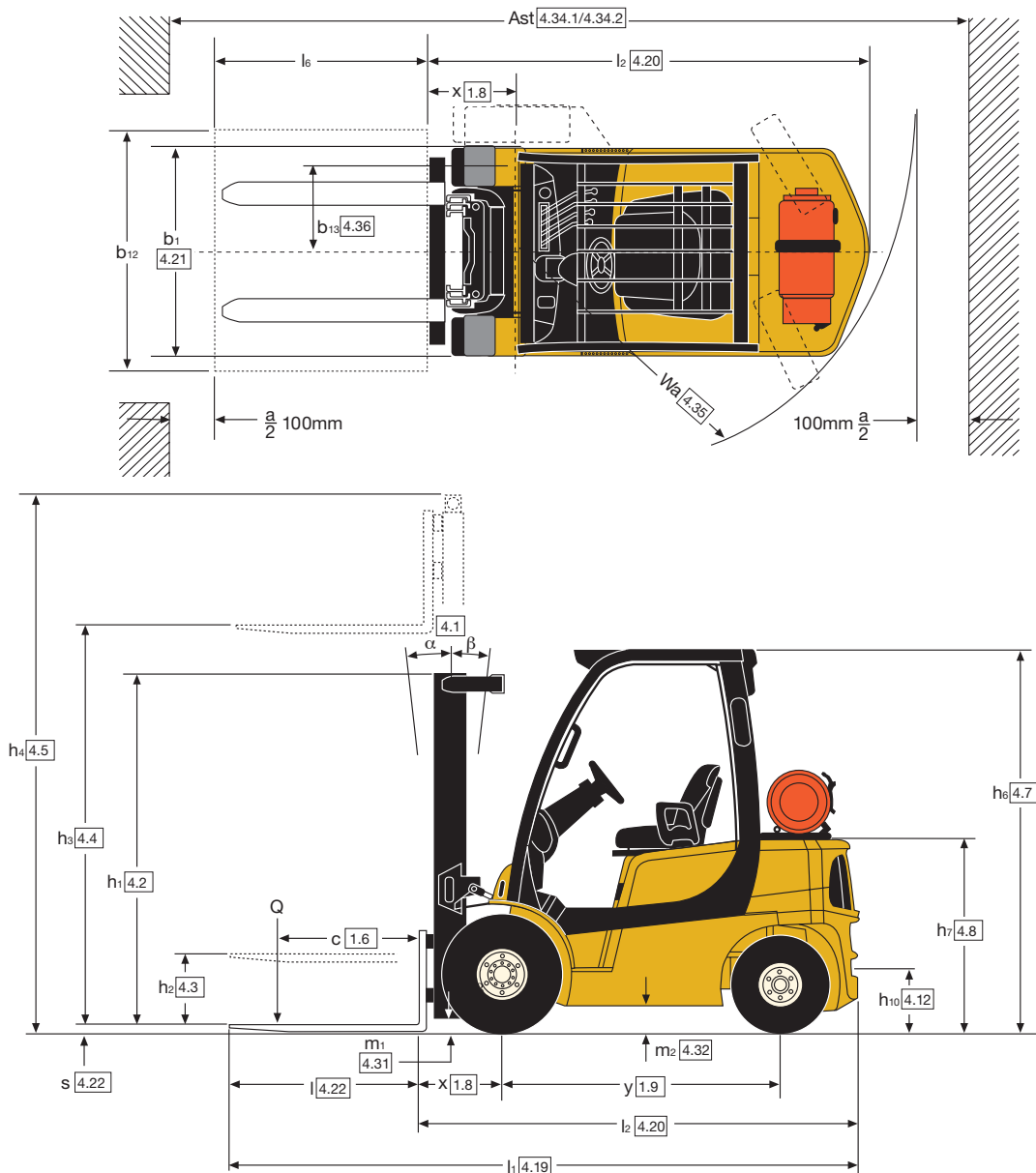

Engine Specifications

PSI 2.4L, LPG

Base, Value

4 Cylinder	Overhead valve
Displacement	2.4 litre
Power	44.0kW @ 2,700rpm
Torque	164Nm @ 2,000rpm
Air Filtration	2 stage, dry type
Emission Control	Closed loop

Kubota 2.5L, LPG

Productivity

4 Cylinder	Overhead valve
Displacement	2.5 litre
Power	43.9kW @ 2,500rpm
Torque	171Nm @ 1,800rpm
Air Filtration	2 stage, dry type
Emission Control	Closed loop

Options

- Powertrain protection system
- Premium monitoring package
- Accumulator
- Keyless start (with auxiliary key switch)
- Traction speed limiter
- Heavy-duty "Combi Cooler" radiator
- Swing-out, drop-down EZ-Tank bracket
- Return-to-set tilt
- Swivel full suspension seat
- Foot directional control
- Operator password
- Alarm-reverse
- Amber strobe light - continuous activated
- Impact monitor
- Load weight indicator

Masts

A full range of Yale 2-stage LFL and 2-stage and 3-stage FFL masts are available.

The new Yale masts are designed for maximum visibility, with widely spaced channels, lift chains and main lift cylinders.

GLP 20VX, GLP 25VX Mast details and capacity ratings (kg) - Superelastic tyres

Model		GLP 20 VX											GLP 25 VX					
Tyre size, front		7.00 x 12											7.00 x 12					
Overall width, front		1157mm											1157mm					
Mast	h ₁ (mm)	h _{2+s} (mm)	h _{3+s} (mm)	h ₄ (mm)	Tilt		Forks			ISS & FP			Forks			ISS & FP		
					F	B	Load centre (kg)			Load centre (kg)			Load centre (kg)			Load centre (kg)		
							500	600	700	500	600	700	500	600	700	500	600	700
2 Stage LFL	2170	140	3290	3904	6	5	2000	1920	1750	2000	1840	1680	2500	2370	2170	2500	2280	2090
	2420	140	3790	4404	6	5	2000	1910	1740	2000	1830	1680	2500	2360	2160	2500	2270	2080
	2770	140	4330	4944	6	5	2000	1890	1730	1990	1810	1660	2500	2350	2150	2480	2250	2070
	3020	140	4830	5444	6	5	1910	1800	1640	1890	1720	1580	2400	2240	2040	2370	2150	1960
2 Stage FFL	2170	1558	3300	3914	6	5	2000	1920	1750	2000	1840	1690	2500	2380	2170	2500	2280	2090
	1970	1382	4350	4938	6	5	2000	1880	1720	1970	1790	1640	2500	2380	2170	2500	2280	2090
3 Stage FFL	2170	1582	4950	5538	6	5	1890	1760	1610	1850	1680	1540	2370	2250	2060	2370	2160	1980
	2420	1832	5550	6138	6	5	1760	1630	1490	1720	1560	1430	2240*	2110*	1930*	2220*	2020*	1850*
	2620	2030	6000	6588	6	5	1660	1530	1400	1600	1460	1340	2120*	1990*	1800*	2090*	1900*	1740*

* With wide tread drive tyres (1317 mm width) or dual drive tyres (1601 mm width) - required for this rating. h₂ & h₄ are less loadbackrest.

GLP 30VX, GLP 35VX Mast details and capacity ratings (kg) - Superelastic tyres

Model		GLP 30 VX											GLP 35 VX					
Tyre size, front		28 x 9-15											28 x 9-15					
Overall width, front		1186mm											1186mm					
Mast	h ₁ (mm)	h _{2+s} (mm)	h _{3+s} (mm)	h ₄ (mm)	Tilt		Forks			ISS & FP			Forks			ISS & FP		
					F	B	Load centre (kg)			Load centre (kg)			Load centre (kg)			Load centre (kg)		
							500	600	700	500	600	700	500	600	700	500	600	700
2 Stage LFL	2195	150	3105	3809	6	5	3000	2820	2580	2970	2700	2480	3500	3310	3030	3490	3180	2920
	2445	150	3605	4309	6	5	3000	2810	2570	2950	2690	2470	3500	3300	3020	3480	3170	2910
	2795	150	4105	4809	6	5	3000	2790	2560	2940	2670	2450	3500	3290	3010	3460	3150	2890
	3045	150	4605	5309	6	5	2890	2690	2450	2830	2570	2350	3390	3170	2900	3340	3040	2780
2 Stage FFL	2195	1495	3110	3810	6	5	3000	2820	2580	2960	2700	2480	3500	3310	3030	3490	3180	2920
	1995	1319	4015	4694	6	5	3000	2800	2560	2930	2670	2450	3500	3290	3010	3460	3150	2890
3 Stage FFL	2195	1519	4615	5294	6	5	2900	2700	2470	2830	2580	2370	3400	3190	2920	3350	3050	2800
	2345	1669	4915	5594	6	5	2840	2630	2410	2760	2510	2310	3320*	3110*	2850*	3260	2980	2730
	2445	1769	5215	5894	6	5	2740	2560	2340	2680	2440	2240	3250*	3030*	2780*	3180*	2900*	2660*
	2695	2015	5815	6494	6	5	2610*	2400*	2200*	2510*	2290*	2100*	2950*	2860*	2610*	2970*	2730*	2500*

* With wide tread drive tyres (1317 mm width) or dual drive tyres (1601 mm width) - required for this rating. h₂ & h₄ are less loadbackrest.

GLP 20VX, GLP 25VX Mast details and capacity ratings (kg) - Pneumatic Radial tyres

Model		GLP 20 VX											GLP 25 VX					
Tyre size, front		7.00 R12											7.00 R12					
Overall width, front		1157mm											1157mm					
Mast	h ₁ (mm)	h _{2+s} (mm)	h _{3+s} (mm)	h ₄ (mm)	Tilt		Forks			Integral Sideshift			Forks			Integral Sideshift		
					F	B	Load centre (kg)			Load centre (kg)			Load centre (kg)			Load centre (kg)		
							500	600	700	500	600	700	500	600	700	500	600	700
2 Stage LFL	2170	140	3290	3904	6	5	2000	1920	1750	2000	1840	1680	2500	2370	2170	2500	2280	2090
	2420	140	3790	4404	6	5	2000	1910	1740	2000	1830	1680	2500	2360	2160	2500	2270	2080
	2770	140	4330	4944	6	5	2000	1890	1730	1990	1810	1660	2500	2350	2150	2480	2250	2070
	3020	140	4830	5444	6	5	1910	1790	1630	1890	1720	1570	2390*	2240*	2040*	2360*	2150*	1960*
2 Stage FFL	2170	1558	3300	3914	6	5	2000	1920	1750	2000	1840	1690	2500	2380	2170	2500	2280	2090
	1970	1382	4350	4938	6	5	2000	1880	1720	1970	1790	1640	2500*	2380*	2170*	2500*	2280*	2090*
3 Stage FFL	2170	1582	4950	5538	6	5	1880	1760	1610	1850	1680	1540	2370*	2250*	2060*	2370*	2150*	1980*
	2420	1832	5550	6138	6	5	1760*	1630*	1490*	1710*	1560*	1430*	2240**	2110**	1930**	2220**	2020**	1860**
	2620	2030	6000	6588	6	5	1650*	1520*	1380*	1600*	1450*	1330*	2130**	1990**	1810**	2100**	1910**	1740**

* With wide tread drive tyres (1321 mm width) or dual drive tyres (1601 mm width) - required for this rating. ** Dual Drive tyres (1601 mm width) - required for this rating. h₂ & h₄ are less loadbackrest.

GLP 30VX, GLP 35VX Mast details and capacity ratings (kg) - Pneumatic Radial tyres

Model		GLP 30 VX											GLP 35 VX					
Tyre size, front		225 / 75R15											225 / 75R15					
Overall width, front		1186mm											1186mm					
Mast	h ₁ (mm)	h _{2+s} (mm)	h _{3+s} (mm)	h ₄ (mm)	Tilt		Forks			ISS & FP			Forks			ISS & FP		
					F	B	Load centre (kg)			Load centre (kg)			Load centre (kg)			Load centre (kg)		
							500	600	700	500	600	700	500	600	700	500	600	700
2 Stage LFL	2195	150	3105	3809	6	5	3000	2820	2580	2970	2700	2480	3500	3310	3030	3490	3180	2920
	2445	150	3605	4309	6	5	3000	2810	2570	2950	2690	2470	3500	3300	3020	3480	3170	2910
	2795	150	4105	4809	6	5	3000	2790	2560	2940	2670	2450	3500	3290	3010	3460	3150	2890
	3045	150	4605	5309	6	5	2890	2690	2450	2820	2570	2350	3340	3170	2890	3340	3040	2780
2 Stage FFL	2195	1495	3110	3810	6	5	3000	2820	2580	2960	2700	2480	3500	3310	3030	3490	3180	2920
	1995	1319	4015	4694	6	5	3000	2800	2560	2930	2670	2450	3500*	3290*	3010*	3430	3150	2890
3 Stage FFL	2195	1519	4615	5294	6	5	2900*	2700*	2470*	2830*	2580*	2370*	3400*	3190*	2920*	3350*	3050*	2800*
	2345	1669	4915	5594	6	5	2830*	2630*	2400*	2750*	2510*	2300*	3330**	3110**	2850**	3270**	2980**	2730**
	2445	1769	5215	5894	6	5	2760*	2550*	2340*	2680*	2440*	2240*	3250**	3040**	2780**	3190**	2900**	2670**
	2695	2015	5815	6494	6	5	2610**	2400**	2190**	2510**	2290**	2090**	3080**	2860**	2610**	3000**	2740**	2500**

* With wide tread drive tyres (1321 mm width) or dual drive tyres (1601 mm width) - required for this rating. ** Dual Drive tyres (1601 mm width) - required for this rating. h₂ & h₄ are less loadbackrest.

VDI 2198 – General Specifications, LPG powered GLP20VX, GLP25VX

Distinguishing mark	1.1	Manufacturer (abbreviation)		Yale	Yale	Yale	
	1.2	Manufacturer's type designation				GLP 20VX	
		Engine/Transmission		PSI 2.4L Standard Electronic, 1-Speed	PSI 2.4L Techtronix 100, 1-Speed	Kubota 2.5L Techtronix 100, 1-Speed	
		Model		Base	Value	Productivity	
		Brake Type		Drum brakes	ADS Drum or Oil-immersed	Oil-immersed	
	1.3	Drive: electric (battery or mains), diesel, petrol, fuel gas		LPG	LPG	LPG	
	1.4	Operator type: hand, pedestrian, standing, seated, orderpicker		Seated	Seated	Seated	
	1.5	Rated capacity / rated load	Q (t)	2.0	2.0	2.0	
	1.6	Load centre distance	c (mm)	500	500	500	
Weights	1.8	Load distance, centre of drive axle to fork	x (mm)	471	471	471	
	1.9	Wheelbase	y (mm)	1623	1623	1623	
	2.1	Service weight	kg	3515	3515	3515	
	2.2	Axle loading, laden front / rear	kg	5003 / 512	5003 / 512	5003 / 512	
	2.3	Axle loading, unladen front / rear	kg	1807 / 1708	1807 / 1708	1807 / 1708	
	3.1	Tyres: P = pneumatic, V = cushion, SE = superelastic		SE	SE	SE	
	Tyres/chassis	3.2	Tyre size, front		7.00 x 12 - 12	7.00 X 12 - 12	7.00 x 12 - 12
3.3		Tyre size, rear		6.00 x 9	6.00 x 9	6.00 x 9	
3.5		Number of wheels, front/rear (x = driven wheels)		2x / 2	2x / 2	2x / 2	
3.6		Tread, front	b ₁₀ (mm)	965	965	965	
3.7		Tread, rear	b ₁₁ (mm)	967	967	967	
Dimensions		4.1	Tilt of mast/fork carriage, forward / backward	α / β (°)	6 / 5	6 / 5	6 / 5
		4.2	Height, mast lowered	h ₁ (mm)	2170	2170	2170
	4.3	Free lift ▼	h ₂ (mm)	140	140	140	
	4.4	Lift ▼	h ₃ (mm)	3250	3250	3250	
	4.5	Height, mast extended +	h ₄ (mm)	3904	3904	3904	
	4.7	Height of overhead guard (cabin) ○	h ₆ (mm)	2160	2160	2160	
	4.71	Cab height (open cab)	(mm)	2181	2181	2181	
	4.8	Seat height relating to SIP/stand height ✕	h ₇ (mm)	1061	1061	1061	
	4.12	Coupling height	h ₁₁₀ (mm)	365	365	365	
	4.19	Overall length	l ₁ (mm)	3486	3486	3486	
	4.20	Length to face of forks	l ₂ (mm)	2486	2486	2486	
	4.21	Overall width □	b ₁ (mm)	1157 / 1317 / 1601	1157 / 1317 / 1601	1157 / 1317 / 1601	
	4.22	Fork dimensions ISO 2331	s/e/l (mm)	40 x 100 x 1000	40 x 100 x 1000	40 x 100 x 1000	
	4.23	Fork carriage ISO 2328, class/type A, B		II A	II A	II A	
	4.24	Fork carriage width ▶	b ₃ (mm)	1067	1067	1067	
	4.31	Ground clearance, laden, below mast	m ₁ (mm)	107	107	107	
	4.32	Ground clearance, centre of wheelbase	m ₂ (mm)	160	160	160	
	4.33	Load dimension b ₁₂ × l ₆ crossways	b ₁₂ × l ₆ (mm)	1000 × 1200	1000 × 1200	1000 × 1200	
	4.34	Aisle width predetermined load dimensions	A _{st} (mm)	3820	3820	3820	
	4.34.1	Aisle width with pallets 1000mm x 1200mm crossways	A _{st} (mm)	3820	3820	3820	
	4.34.2	Aisle width with pallets 800mm wide x 1200mm lengthways	A _{st} (mm)	4020	4020	4020	
4.35	Turning radius	W _a (mm)	2149	2149	2149		
4.36	Internal turning radius	b ₁₃ (mm)	629	629	629		
4.41	90° intersecting aisle (with pallet W = 1200mm, L = 1000mm)	(mm)	1987	1987	1987		
4.42	Step height (from ground to running board)	(mm)	707	702	702		
4.43	Step height (between intermediate steps between running board and floor)	(mm)	382	382	382		
Performance data	5.1	Travel speed laden/unladen	km/h	17.3 / 18.0	17.3 / 18.0	16.7 / 17.0	
	5.1.1	Travel speed, laden/unladen, backwards	km/h	17.3 / 18.0	17.3 / 18.0	16.7 / 17.0	
	5.2	Lift speed, laden/unladen	m/s	0.61 / 0.63	0.61 / 0.63	0.62 / 0.64	
	5.3	Lowering speed, laden/unladen	m/s	0.58 / 0.50	0.58 / 0.50	0.58 / 0.50	
	5.5	Drawbar pull, laden/unladen *	N	18720 / 11000	18720 / 11000	19085 / 11000	
	5.6	Maximum drawbar pull laden/unladen,	N	22100 / 11000	22100 / 11000	22290 / 11000	
	5.7	Gradeability, laden/unladen **	%	19.0 / 29.8	19.0 / 29.8	25.5 / 32.1	
	5.9	Acceleration time, laden/unladen	s	4.8 / 4.3	4.8 / 4.3	4.5 / 4.0	
	5.10	Service brake		Hydraulic	Hydraulic	Hydraulic	
	Combustion engine	7.1	Engine manufacturer/type		PSI 2.4L	PSI 2.4L	Kubota 2.5L
7.2		Engine power according to ISO1585	kW	44.0	44.0	43.9	
7.3		Rated speed	min-1	2700	2700	2500	
7.4		Number of cylinders/displacement	(-)/cm ³	4 / 2351	4 / 2351	4 / 2491	
7.5		Fuel consumption according to VDI cycle	l/h or kg/h	2.5	2.5	2.6	
Addition data	8.1	Type of drive unit		Hydrodynamic	Hydrodynamic	Hydrodynamic	
	10.1	Operating pressure for attachments	bar	0 - 155	0 - 155	0 - 155	
	10.2	Oil volume for attachments ◊	l/min	62	62	66	
	10.3	Hydraulic oil tank, capacity	litres	45.8	45.8	45.8	
	10.4	Fuel tank, capacity	litres	52.8	52.8	52.8	
	10.7	Sound pressure level at the driver's seat ★	dB(A)	77	77	78	
	10.7.1	Sound power level during the workcycle ◆	dB(A)	97	97	96	
	10.7.2	Guaranteed sound power 2000/14/EC	dB(A)	101	101	100	
	10.8	Towing coupling, type DIN		Pin	Pin	Pin	

** Engine data based on max. capacity displacement. ○ h6 subject to +/- 5 mm tolerance. □ Standard/Wide/Dual. When wet axle selected values are (1186 / 1321 / 1601) for all capacities. * at 1.6km/h.
 ▲ Top of forks. ✕ Full suspension seat in depressed position. ◆ Add 32mm with load backrest. ** at 4.8km/h.
 ♣ Without load backrest. ★ LPAZ, measured according to the test cycles and based on the weighting values contained in EN12053. ◊ Variable.

Yale	Yale	Yale	Yale	Yale	1.1	
	GLP 25VX				1.2	
Kubota 2.5L Techtronix 200, 2-Speed	PSI 2.4L Standard Electronic, 1-Speed	PSI 2.4L Techtronix 100, 1-Speed	Kubota 2.5L Techtronix 100, 1-Speed	Kubota 2.5L Techtronix 200, 2-Speed	Distinguishing mark	
Productivity	Base	Value	Productivity	Productivity		
Oil-immersed	Drum brakes	ADS Drum or Oil-immersed	Oil-immersed	Oil-immersed		
LPG	LPG	LPG	LPG	LPG		1.3
Seated	Seated	Seated	Seated	Seated		1.4
2.0	2.5	2.5	2.5	2.5		1.5
500	500	500	500	500		1.6
471	471	471	471	471		1.8
1623	1623	1623	1623	1623		1.9
3515	3853	3853	3853	3853		2.1
5003 / 512	5732 / 621	5732 / 621	5732 / 621	5732 / 621	2.2	
1807 / 1708	1737 / 2116	1737 / 2116	1737 / 2116	1737 / 2116	2.3	
SE	SE	SE	SE	SE	3.1	
7.00 x 12 - 12	7.00 x 12 - 12	7.00 x 12 - 12	7.00 x 12 - 12	7.00 x 12 - 12	3.2	
6.00 x 9	6.00 x 9	6.00 x 9	6.00 x 9	6.00 x 9	3.3	
2x / 2	2x / 2	2x / 2	2x / 2	2x / 2	3.5	
965	965	965	965	965	3.6	
967	967	967	967	967	3.7	
6 / 5	6 / 5	6 / 5	6 / 5	6 / 5	4.1	
2170	2170	2170	2170	2170	4.2	
140	140	140	140	140	4.3	
3250	3250	3250	3250	3250	4.4	
3904	3904	3904	3904	3904	4.5	
2160	2160	2160	2160	2160	4.7	
2181	2181	2181	2181	2181	4.71	
1061	1061	1061	1061	1061	4.8	
365	365	365	365	365	4.12	
3486	3559	3559	3559	3559	4.19	
2486	2559	2559	2559	2559	4.20	
1157 / 1317 / 1601	1157 / 1317 / 1601	1157 / 1317 / 1601	1157 / 1317 / 1601	1157 / 1317 / 1601	4.21	
40 x 100 x 1000	40 x 100 x 1000	40 x 100 x 1000	40 x 100 x 1000	40 x 100 x 1000	4.22	
II A	II A	II A	II A	II A	4.23	
1067	1067	1067	1067	1067	4.24	
107	107	107	107	107	4.31	
160	160	160	160	160	4.32	
1000 x 1200	1000 x 1200	1000 x 1200	1000 x 1200	1000 x 1200	4.33	
3820	3887	3887	3887	3887	4.34	
3820	3887	3887	3887	3887	4.34.1	
4020	4087	4087	4087	4087	4.34.2	
2149	2216	2216	2216	2216	4.35	
629	629	629	629	629	4.36	
1987	2020	2020	2020	2020	4.41	
702	707	702	702	702	4.42	
382	382	382	382	382	4.43	
20.8 / 21.2	17.3 / 18.0	17.3 / 18.0	16.7 / 17.0	20.8 / 21.2	5.1	
16.3 / 16.6	17.3 / 18.0	17.3 / 18.0	16.7 / 17.0	16.3 / 16.6	5.1.1	
0.58 / 0.61	0.61 / 0.63	0.61 / 0.63	0.62 / 0.64	0.57 / 0.61	5.2	
0.58 / 0.50	0.58 / 0.50	0.58 / 0.50	0.58 / 0.50	0.58 / 0.50	5.3	
20875 / 11000	18580 / 11450	18580 / 11450	18946 / 10500	20825 / 10500	5.5	
21800 / 11000	22000 / 10500	22000 / 10500	22150 / 10500	21800 / 10500	5.6	
26.5 / 32.1	16.0 / 29.0	16.0 / 29.0	21.8 / 28.0	22.7 / 28.0	5.7	
4.9 / 4.3	5.1 / 4.4	5.1 / 4.4	4.7 / 4.1	5.1 / 4.4	5.9	
Hydraulic	Hydraulic	Hydraulic	Hydraulic	Hydraulic	5.10	
Kubota 2.5L	PSI 2.4L	PSI 2.4L	Kubota 2.5L	Kubota 2.5L	7.1	
43.9	44.0	44.0	43.9	43.9	7.2	
2500	2700	2700	2500	2500	7.3	
4 / 2491	4 / 2351	4 / 2351	4 / 2491	4 / 2491	7.4	
2.7	2.7	2.7	2.8	2.9	7.5	
Hydrodynamic	Hydrodynamic	Hydrodynamic	Hydrodynamic	Hydrodynamic	8.1	
0 - 155	0 - 155	0 - 155	0 - 155	0 - 155	10.1	
66	62	62	66	66	10.2	
45.8	45.8	45.8	45.8	45.8	10.3	
52.8	52.8	52.8	52.8	52.8	10.4	
78	77	77	78	78	10.7	
96	97	97	96	96	10.7.1	
100	101	101	100	100	10.7.2	
Pin	Pin	Pin	Pin	Pin	10.8	

Distinguishing mark

Weights

Tyres/chassis

Dimensions

Performance data

Combustion engine

Addition data

◆ LWAZ, measured according to the test cycles and based on the weighting values contained in EN12053. **Base specification truck based on:** 3290mm (GLP20/25VX) / 3105mm (GLP30/35VX) top of forks 2 stage LFL Standard carriage, 1000mm forks and manual levers. **Value and Productivity specification truck based on:** 3290mm (GLP20/25VX) / 3105mm (GLP30/35VX) top of forks 2 stage LFL Standard carriage, 1000mm forks and manual levers. For Value trucks fitted with manual levers, the values for lines 5.2 and 7.5 are as on the Base VDI table.

VDI 2198 – General Specifications, LPG powered GLP30VX, GLP35VX

Distinguishing mark	1.1	Manufacturer (abbreviation)		Yale	Yale		
	1.2	Manufacturer's type designation			GLP 30VX		
		Engine/Transmission		PSI 2.4L Standard Electronic, 1-Speed	PSI 2.4L Techtronix 100, 1-Speed	Kubota 2.5L Techtronix 100, 1-Speed	
		Model		Base	Value	Productivity	
		Brake Type		Drum brakes	ADS Drum or Oil-immersed	Oil-immersed	
	1.3	Drive: electric (battery or mains), diesel, petrol, fuel gas		LPG	LPG	LPG	
	1.4	Operator type: hand, pedestrian, standing, seated, orderpicker		Seated	Seated	Seated	
	1.5	Rated capacity / rated load	Q (t)	3.0	3.0	3.0	
	1.6	Load centre distance	c (mm)	500	500	500	
Weights	1.8	Load distance, centre of drive axle to fork	x (mm)	483	483	483	
	1.9	Wheelbase	y (mm)	1623	1623	1623	
	2.1	Service weight	kg	4329	4329	4329	
	2.2	Axle loading, laden front / rear	kg	6619 / 710	6619 / 710	6619 / 710	
	2.3	Axle loading, unladen front / rear	kg	1802 / 2527	1802 / 2527	1802 / 2527	
	3.1	Tyres: P = pneumatic, V = cushion, SE = superelastic		SE	SE	SE	
	Tyres/chassis	3.2	Tyre size, front		28 x 9 - 15	28 x 9 - 15	28 x 9 - 15
		3.3	Tyre size, rear		6.50 x 10	6.50 x 10	6.50 x 10
		3.5	Number of wheels, front/rear (x = driven wheels)		2x / 2	2x / 2	2x / 2
3.6		Tread, front	b ₁₀ (mm)	965	965	965	
3.7		Tread, rear	b ₁₁ (mm)	967	967	967	
Dimensions		4.1	Tilt of mast/fork carriage, forward / backward	α / β (°)	6 / 5	6 / 5	6 / 5
		4.2	Height, mast lowered	h ₁ (mm)	2195	2195	2195
	4.3	Free lift ▼	h ₂ (mm)	140	140	140	
	4.4	Lift ▼	h ₃ (mm)	3055	3055	3055	
	4.5	Height, mast extended +	h ₄ (mm)	3809	3809	3809	
	4.7	Height of overhead guard (cabin) ○	h ₆ (mm)	2185	2185	2185	
	4.71	Cab height (open cab)	(mm)	2206	2206	2206	
	4.8	Seat height relating to SIP/stand height ✕	h ₇ (mm)	1086	1086	1086	
	4.12	Coupling height	h ₁₁₀ (mm)	390	390	390	
	4.19	Overall length	l ₁ (mm)	3633	3633	3633	
	4.20	Length to face of forks	l ₂ (mm)	2633	2633	2633	
	4.21	Overall width □	b ₁ (mm)	1186 / 1321 / 1601	1186 / 1321 / 1601	1186 / 1321 / 1601	
	4.22	Fork dimensions ISO 2331	s/e/l (mm)	50 x 120 x 1000	50 x 120 x 1000	50 x 120 x 1000	
	4.23	Fork carriage ISO 2328, class/type A, B		III A	III A	III A	
	4.24	Fork carriage width ▶	b ₃ (mm)	1067	1067	1067	
	4.31	Ground clearance, laden, below mast	m ₁ (mm)	132	132	132	
	4.32	Ground clearance, centre of wheelbase	m ₂ (mm)	185	185	185	
	4.33	Load dimension b ₁₂ x l ₆ crossways	b ₁₂ x l ₆ (mm)	1000 x 1200	1000 x 1200	1000 x 1200	
	4.34	Aisle width predetermined load dimensions	A _{st} (mm)	3955	3955	3955	
	4.34.1	Aisle width with pallets 1000mm x 1200mm crossways	A _{st} (mm)	3955	3955	3955	
	4.34.2	Aisle width with pallets 800mm wide x 1200mm lengthways	A _{st} (mm)	4155	4155	4155	
4.35	Turning radius	W _a (mm)	2277	2277	2277		
4.36	Internal turning radius	b ₁₃ (mm)	618	618	618		
4.41	90° intersecting aisle (with pallet W = 1200mm, L = 1000mm)	(mm)	2077	2077	2077		
4.42	Step height (from ground to running board)	(mm)	727	727	727		
4.43	Step height (between intermediate steps between running board and floor)	(mm)	407	407	407		
Performance data	5.1	Travel speed laden/unladen	km/h	19.1 / 20.3	19.1 / 20.3	17.8 / 18.2	
	5.1.1	Travel speed, laden/unladen, backwards	km/h	19.1 / 20.3	19.1 / 20.3	17.8 / 18.2	
	5.2	Lift speed, laden/unladen	m/s	0.53 / 0.55	0.53 / 0.55	0.55 / 0.56	
	5.3	Lowering speed, laden/unladen	m/s	0.53 / 0.47	0.53 / 0.47	0.53 / 0.47	
	5.5	Drawbar pull, laden/unladen *	N	17054 / 10800	17054 / 10800	17380 / 10800	
	5.6	Maximum drawbar pull laden/unladen,	N	19950 / 10800	19950 / 10800	20100 / 10800	
	5.7	Gradeability, laden/unladen **	%	16.9 / 25.0	16.9 / 25.0	17.6 / 26.1	
	5.9	Acceleration time, laden/unladen	s	5.3 / 4.5	5.3 / 4.5	4.9 / 4.2	
	5.10	Service brake		Hydraulic	Hydraulic	Hydraulic	
	Combustion engine	7.1	Engine manufacturer/type		PSI 2.4L	PSI 2.4L	Kubota 2.5L
7.2		Engine power according to ISO1585	kW	44.0	44.0	43.9	
7.3		Rated speed	min-1	2700	2700	2500	
7.4		Number of cylinders/displacement	(-)/cm ³	4 / 2351	4 / 2351	4 / 2491	
7.5		Fuel consumption according to VDI cycle	l/h or kg/h	3.1	3.1	3.0	
Addition data	8.1	Type of drive unit		Hydrodynamic	Hydrodynamic	Hydrodynamic	
	10.1	Operating pressure for attachments	bar	0 - 155	0 - 155	0 - 155	
	10.2	Oil volume for attachments ◇	l/min	62	62	66	
	10.3	Hydraulic oil tank, capacity	litres	45.8	45.8	45.8	
	10.4	Fuel tank, capacity	litres	52.8	52.8	52.8	
	10.7	Sound pressure level at the driver's seat ★	dB(A)	77	77	78	
	10.7.1	Sound power level during the workcycle ◆	dB(A)	97	97	96	
	10.7.2	Guaranteed sound power 2000/14/EC	dB(A)	101	101	100	
	10.8	Towing coupling, type DIN		Pin	Pin	Pin	

** Engine data based on max. capacity displacement. ○ h6 subject to +/- 5 mm tolerance. □ Standard/Wide/Dual. When wet axle selected values are (1186 / 1321 / 1601) for all capacities. * at 1.6km/h. ★ LPAZ, measured according to the test cycles and based on the weighting values contained in EN12053.

▲ Top of forks. ✕ Full suspension seat in depressed position. ▶ Add 32mm with load backrest. ** at 4.8km/h. ◇ Variable.

♣ Without load backrest.

Yale	Yale	Yale	Yale	Yale	1.1	
	GLP 35VX				1.2	
Kubota 2.5L Techtronix 200, 2-Speed	PSI 2.4L Standard Electronic, 1-Speed	PSI 2.4L Techtronix 100, 1-Speed	Kubota 2.5L Techtronix 100, 1-Speed	Kubota 2.5L Techtronix 200, 2-Speed	Distinguishing mark	
Productivity	Base	Value	Productivity	Productivity		
Oil-immersed	Drum brakes	ADS Drum or Oil-immersed	Oil-immersed	Oil-immersed		
LPG	LPG	LPG	LPG	LPG		1.3
Seated	Seated	Seated	Seated	Seated		1.4
3.0	3.5	3.5	3.5	3.5		1.5
500	500	500	500	500		1.6
483	483	483	483	483		1.8
1623	1700	1700	1700	1700		1.9
4329	4646	4646	4646	4646		2.1
6619 / 710	7283 / 863	7283 / 863	7283 / 863	7283 / 863	2.2	
1802 / 2527	1761 / 2885	1761 / 2885	1761 / 2885	1761 / 2885	2.3	
SE	SE	SE	SE	SE	3.1	
28 x 9 - 15	28 x 9 - 15	28 x 9 - 15	28 x 9 - 15	28 x 9 - 15	3.2	
6.50 x 10	6.50 x 10	6.50 x 10	6.50 x 10	6.50 X 10	3.3	
2x / 2	2x / 2	2x / 2	2x / 2	2x / 2	3.5	
965	965	965	965	965	3.6	
967	967	967	967	967	3.7	
6 / 5	6 / 5	6 / 5	6 / 5	6 / 5	4.1	
2195	2195	2195	2195	2195	4.2	
140	140	140	140	140	4.3	
3055	3055	3055	3055	3055	4.4	
3809	3809	3809	3809	3809	4.5	
2185	2185	2185	2185	2185	4.7	
2206	2206	2206	2206	2206	4.71	
1086	1086	1086	1086	1086	4.8	
390	390	390	390	390	4.12	
3633	3734	3734	3734	3734	4.19	
2633	2734	2734	2734	2734	4.20	
1186 / 1321 / 1601	1186 / 1321 / 1601	1186 / 1321 / 1601	1186 / 1321 / 1601	1186 / 1321 / 1601	4.21	
50 x 120 x 1000	50 x 120 x 1000	50 x 120 X 1000	50 x 120 x 1000	50 x 120 X 1000	4.22	
III A	III A	III A	III A	III A	4.23	
1067	1067	1067	1067	1067	4.24	
132	132	132	132	132	4.31	
185	185	185	185	185	4.32	
1000 x 1200	1000 x 1200	1000 x 1200	1000 x 1200	1000 x 1200	4.33	
3955	4058	4058	4058	4058	4.34	
3955	4058	4058	4058	4058	4.34.1	
4155	4258	4258	4258	4258	4.34.2	
2277	2380	2380	2380	2380	4.35	
618	647	647	647	647	4.36	
2077	2111	2111	2111	2111	4.41	
727	727	727	727	727	4.42	
407	407	407	407	407	4.43	
22.0 / 22.7	19.1 / 20.3	19.1 / 20.3	17.8 / 18.2	22.0 / 22.7	5.1	
17.8 / 17.9	19.1 / 20.3	19.1 / 20.3	17.8 / 18.2	17.8 / 17.9	5.1.1	
0.49 / 0.53	0.53 / 0.55	0.53 / 0.55	0.56 / 0.56	0.48 / 0.53	5.2	
0.53 / 0.47	0.53 / 0.47	0.53 / 0.47	0.53 / 0.47	0.53 / 0.47	5.3	
19270 / 10800	16905 / 10600	16905 / 10600	17230 / 10600	19120 / 10600	5.5	
21800 / 10800	19800 / 10600	19800 / 10600	19950 / 10600	21800 / 10600	5.6	
18.5 / 26.1	15.0 / 23.0	15.0 / 23.0	15.6 / 23.9	16.4 / 23.9	5.7	
5.4 / 4.6	5.6 / 4.6	5.6 / 4.6	5.2 / 4.3	5.6 / 4.7	5.9	
Hydraulic	Hydraulic	Hydraulic	Hydraulic	Hydraulic	5.10	
Kubota 2.5L	PSI 2.4L	PSI 2.4L	Kubota 2.5L	Kubota 2.5L	7.1	
43.9	44.0	44.0	43.9	43.9	7.2	
2500	2700	2700	2500	2500	7.3	
4 / 2491	4 / 2351	4 / 2351	4 / 2491	4 / 2491	7.4	
3.2	3.4	3.4	3.2	3.4	7.5	
Hydrodynamic	Hydrodynamic	Hydrodynamic	Hydrodynamic	Hydrodynamic	8.1	
0 - 155	0 - 155	0 - 155	0 - 155	0 - 155	10.1	
66	62	62	66	66	10.2	
45.8	45.8	45.8	45.8	45.8	10.3	
52.8	52.8	52.8	52.8	52.8	10.4	
78	77	77	78	78	10.7	
96	97	97	96	96	10.7.1	
100	101	101	100	100	10.7.2	
Pin	Pin	Pin	Pin	Pin	10.8	

Distinguishing mark

Weights

Tyres/chassis

Dimensions

Performance data

Combustion engine

Addition data

◆ LWAZ, measured according to the test cycles and based on the weighting values contained in EN12053. **Base specification truck based on:** 3290mm (GLP20/25VX) / 3105mm (GLP30/35VX) top of forks 2 stage LFL Standard carriage, 1000mm forks and manual levers. **Value and Productivity specification truck based on:** 3290mm (GLP20/25VX) / 3105mm (GLP30/35VX) top of forks 2 stage LFL Standard carriage, 1000mm forks and manual levers. For Value trucks fitted with manual levers, the values for lines 5.2 and 7.5 are as on the Base VDI table.

VX series

Models: LPG 20VX, LPG 25VX, LPG 30VX, LPG 35VX



Yale Veracitor VX Series

This series of trucks is available in three configurations.

The Veracitor Base truck offers first-rate performance for a wide variety of applications, geared to minimise cost of acquisition without compromising performance.

The Veracitor Value truck provides excellent performance and is optimised for lowest hourly operating cost. The Veracitor Productivity truck delivers maximum performance for medium to heavy duty applications with state-of-the-art features and industry leading power.

Engines

Yale Veracitor truck is powered by a range of heavy duty industrial engines, designed to deliver power efficiently over a 20,000 hour design life with 500 hour service intervals. All engines feature Cast Iron Blocks and a 5 main bearing design; engines are fully isolated from the frame and axle to prevent direct transmission of noise and vibration, resulting in low vehicle noise and vibration levels.

Variations in LPG fuel and its higher burning temperatures present challenges for converted Gasoline Engines and Yale has developed state of the art electronic fuel injection systems, which use closed loop control to maintain proper fuelling in all operating conditions.

These advanced Industrial Engines feature coil over plug spark designs, and especially hardened intake and exhaust valve seats to ensure long operating life.

The PSI 2.4L LPG engine delivers excellent performance combined with low fuel consumption and minimal noise. It has a robust design with a cast iron cylinder block and no plug wires, distributor caps or rotors.

The high performance Kubota 2.5L LPG engine maximises performance and productivity for intensive operations, and with Cast Iron head and special 9.5 Litre Oil capacity is designed to do so reliably for the life of the truck. Advanced engine controls allow fuel mapping to be optimised to allow highly efficient operation in ECO-eLo (Fuel efficiency) mode, with minimum loss of performance.

Masts

The range of masts provides the driver with excellent visibility both through the mast and panoramically. The mast has a robust design and offers excellent rigidity particularly at full lift height. They are manufactured without compromise to provide robust and reliable performance, with minimal maintenance cost over the lifetime of the product.

Transmission

Four transmission selections are available with multiple engine configurations for a wide variety of material handling applications.

1) Standard Electronic features electronic inching, electric shift control, neutral start switch, antirestart protection and heavy duty

clutch packs.

2) The Techtronix™ 100 has all the Standard Electronic features plus an Auto Deceleration System.

3) The Techtronix™ 200 has all the Techtronix™ 100 features, plus Two Speed Auto Shift (2 x forward, 1 x reverse).

Load Sensing Hydraulics

With AccuTouch™ electrohydraulic controls Load Sensing Hydraulics (LSH) delivers increased operational efficiency, offering a 15% reduction in fuel consumption on the VDI cycle, with no loss in productivity*. Variable displacement piston pumps match the flow rate and lifting speed continuously to the demands of the duty cycle. O-ring face seal fittings are used in all high pressure hydraulic connections. The engine therefore supplies power to the hydraulic pumps only when required, so more power is available for driving. With LSH Yale also offers an ECO-eLo (Fuel Efficiency) mode, reducing engine speed by 20% and optimising throttle response, so that the truck operates in the most economical power range. This results in a reduction in fuel consumption of a further 5%* but has a limited effect on overall truck productivity under application conditions. The ECO-eLo mode also delivers lower noise levels by up to 3dB(A). If a faster work rate, or higher productivity is required, the truck can easily be reprogrammed to HiP (High Performance) mode of operation through the dash display, with access secured by a unique customer password.

Autospeed Hydraulics

With Autospeed Hydraulics the engine speed is automatically increased to provide full hydraulic power. The Pacesetter VSM maintains the current travel speed (or prevents travel) until the operator steps on the accelerator. No operator inching is required and productivity and efficiency is increased by simplifying operator actions.

Cooling System

The cooling system employs a 43cm blade pusher type fan. A permanently lubricated water pump and a high capacity, cross-flow radiator ensures rapid heat dissipation. The sealed cooling system operates at 15psi, the coolant recovery tank allows visual inspection of coolant level. A transmission oil cooler is integrated into the radiator, located in the side tank. The optional combi-cooler radiator features an externally mounted transmission oil cooler for increased heat transfer capability. All radiators are soft mounted for durability.

Drive Axle

The drive axle is designed to withstand heavy duty applications and absorb shock loads. It is a "self-contained" assembly isolated from the transmission by a heavy-duty rubber isolator. The axle shafts utilize a "rolled fillet" root spline design for increased resistance to torsion stress. A magnetic sump plug collects any

metal particles circulating in the axle oil to prevent component wear.

Brakes

Brakes are duo-servo hydraulic, selfenergizing, and automatic adjusting drum brake assemblies.

The Value and Productivity models have oil immersed brakes as standard. The single circuit master cylinder has a sealed fluid reservoir and features a fluid level sensor which activates an indicator light on the instrument panel.

Hydraulic Power Steering

Hydrostatic steering provides responsive control and eliminates mechanical linkages for reduced surface shock and simplified maintenance. The steering wheel is 30cm in diameter with a textured surface grip and spinner knob, and requires only four turns lock-to-lock. The centre mounted steer cylinder is located within the confines of the steer axle for protection.

Steer Axle

Constructed from cast steel, the steer axle is rubber shock mounted to the frame for reduced wear and vibration. The CSE (Continuous Stability Enhancement) system enhances lateral truck stability through reduced steer axle articulation, while simultaneously allowing uncompromised travel on uneven surfaces.

Operator's Compartment

Base truck features cowl mounted hydraulic control levers as standard, positioned on the right side of the steering column. All models are available with AccuTouch™ mini-lever armrest, which features a contoured design, and – in addition to the hydraulic functions – features a horn and direction switch.

The Full Suspension Seat together with the isolated powertrain provide best in class Whole-Body Vibration levels of 0.6m/s², ensuring that the operator remains comfortable throughout the shift and fatigue, aches and pains are kept to a minimum. Automotive-style pedal arrangement with a large, single inch/ brake pedal is standard.

Intellix Vehicle System Management (VSM)

VSM acts as a master truck controller, providing extensive monitoring and control of truck functions and systems. CANbus technology reduces wiring complexity and enables communications between truck systems. The dash display transmits continual feedback to the operator and allows communication of service codes. On-board diagnostics enable quick and easy troubleshooting. The electrical system features sealed connectors and Hall Effect sensors for superior dependability.

(*Yale Productivity Test Cycle: Load Sensing Hydraulics is available on trucks with AccuTouch™ mini-levers and the ECO-eLo function is available on trucks with Techtronix™ transmissions only).

NACCO Materials Handling Limited
trading as **Yale Europe Materials Handling**
Centennial House, Frimley Business Park,
Frimley, Surrey GU16 7SG, United Kingdom.

Tel: +44 (0) 1276 538500 Fax: +44 (0) 1276 538559

www.yale-forklifts.eu

Country of Registration: England. Company Registration Number: 02636775



Safety. This truck conforms to the current EU requirements. Specification is subject to change without notice.

Yale, VERACITOR and  are registered trademarks. "PEOPLE, PRODUCTS, PRODUCTIVITY", PREMIER, Hi-Vis, and CSS are trademarks in the United States and certain other jurisdictions. MATERIALS HANDLING CENTRAL and MATERIAL HANDLING CENTRAL are Service Marks in the United States and certain other jurisdictions.

 is a Registered Copyright. © Yale Europe Materials Handling 2015. All rights reserved.

Truck shown with optional equipment

Printed in The United Kingdom (Q315HG) EN. Publication part no. 290000462 Rev.01