



UX SERIES

BROCHURE

MP20XUX
Electric Walkie
Pallet Truck

2,000kg

MP20XUX

The Yale® electric rider pallet truck MP20XUX delivers low cost of ownership, as well as boosting pallet transportation rates over both short and long distances. These sturdy trucks can optimise vehicle loading and unloading operations while providing the operator with optimum comfort.

PRODUCTIVITY

- Advanced AC control system eliminates the motor brushes, which limits maintenance requirements
- Low skirtings on main chassis
- Side battery roll-out system is very convenient to replace batteries
- Built-in pressure relief valve protects the trucks from overloading
- Emergency power disconnect switch
- Long handle reduces steering effort
- Emergency reversing system in handle
- Low speed switch in the handle
- Variable speed control
- Cold store configuration (option)

OPTIMUM STRUCTURAL DESIGN

- Spring-loaded casters improve lateral stability on uneven floors and enhance truck performance and service life
- Formed heavy gauge steel provides maximum fork strength and longevity
- Pull rod design protects against bending
- Durable plastic covers

SERVICEABILITY

- CANbus technology reduces wiring complexity
- Low battery protection setting extends the battery life
- All pivot points have grease fittings and serviceable bushing, reducing component wear



Handle (Standard)
(Left & Right Handed)



Entry Roller for
Easy Operation



One Sided
(Cold Store)



Two Sided
(Cold Store)

SPECIFICATIONS AND DIMENSIONS

Model	Measurement	MP20XUX
Load capacity	Q (kg)	2000
Load centre distance	c (mm)	600
Load distance, centre of drive axle to fork	x (mm)	815/865/935
Wheelbase	y (mm)	1261
Fork height, lowered	h13 (mm)	82
Tyre size, front	mm	250×70
Tyre size, rear	mm	82×126 (98)
Additional wheels (dimensions)	mm	127×57
Wheels, number front rear (x=driven wheels)		1X+2/2 (4)
Max.lift height	h3 (mm)	202
Height of tiller in drive position min./max.	h14 (mm)	1150/1430
Overall length	l1 (mm)	1710/1760/1830
Length to face of forks	l2 (mm)	610
Overall width	b1 (mm)	775
Fork dimensions	s/e/l (mm)	53×180×1100 (1150/1220)
Width overall forks	b5 (mm)	550/685
Aisle width for pallets 1000×1200 crossways	Ast (mm)	1910/1960/2030
Aisle width for pallets 800×1200 crossways	Ast (mm)	2010/2010/2030
Turning radius	Wa (mm)	1550/1600/1670
Drive motor power	kW	1.2
Lift motor power	kW	0.8
Sound level at the driver's ear according to DIN12503	dB (A)	70
Travel speed, laden/unladen	Km/h	7/7.1
Battery voltage, nominal capacity K5	V/Ah	24/210
Battery weight	Kg	196
Battery dimensions l/w/h	mm	750×170×534
Service weight (with battery)	Kg	720

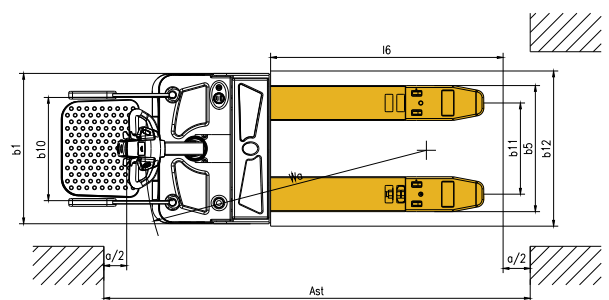
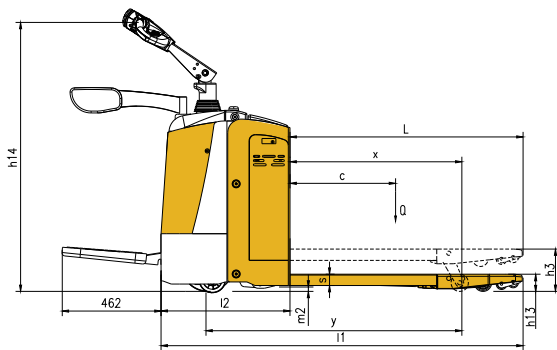

MP20XUX POWER PLUG TYPE



A
Power Plug



F
Power Plug



G
Power Plug

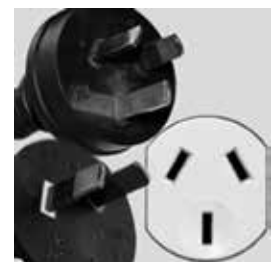

I
Power Plug

About Yale



Yale Lift Truck Technologies leverages over a century of material handling experience and substantial investment in innovation to bring the most advanced technology-driven lift truck solutions to market. The company offers a full line of award-winning lift trucks, including reach trucks, order pickers, turret trucks, pallet jacks and trucks, pallet stackers, tow tractors and counterbalanced forklifts, as well as powerful operator assist solutions, proven robotics and a wide range of power sources to help customers adapt to today's demanding supply chain. Yale and its independent dealer network support these solutions with comprehensive after-sales service, parts, financing and training.

Yale Lift Truck Technologies is a trading name of Hyster-Yale Asia-Pacific Pty Ltd., a wholly owned subsidiary of Hyster-Yale Materials Handling, Inc. (NYSE:HY) which is headquartered in Cleveland, Ohio and operates globally.

MATERIALS HANDLING FOR:

3PL

Auto Parts Distribution

Beverage

Cold & Frozen Foods

Food Distribution

Food Processing

Furniture & Furnishings

Government

Health & Pharma

Home Centers

Retail & E-commerce

Yale Pacific

1/23 Rowood Road, Prospect NSW 2148

Tel: +61 (2) 9795 3800 | Fax: +61 (2) 9792 8484

Yale Asia

16 Tuas Avenue 20, Singapore 638827

Tel: +65 6863 3387 | Fax: +65 6863 3349

yale.com

© 2023 Hyster-Yale Group, Inc., all rights reserved. YALE and  are trademarks of Hyster-Yale Group, Inc. Trucks may be shown with optional equipment and/or features not available in all regions. Specifications and details in this brochure are subject to change without prior notification.