Yale UX Series

Seated Electric Tow Tractor

MT30UX / 3000KG



www.yale.com.au

Yale[®] 
People. Products. Productivity.™

► Overview

MT30UX

The Yale® seated electric tow tractor MT30UX demonstrates intelligent ergonomics, reliable technology and energy efficient features to facilitate operational needs. The low-maintenance design promotes increased productivity and helps reduce operational costs.

► Productivity

- High-power maintenance free AC drive motor
- Impressive pulling performance
- Seamless travel and manoeuvrability
- Rear dual-position tow coupling
- Ergonomic layout to maximise operational efficiency and comfort
- Adjustable seat and steering column
- Multi function LCD dash display
- Automatic electro-magnetic parking brake

► Serviceability

- Easy access for fast and efficient servicing
- Simple, readily available components
- Computer based diagnostics not required

► Safety & Structural Design

- Operator Presence System (OPS)
- Non-slip, uncluttered floor plate
- Drive axle design and low centre of gravity enables excellent stability
- Emergency stop button
- Audible reverse alarm
- High quality, robust components
- Low noise level

► Optional Features

- Battery side extraction
- Keyless key switch (password)
- Blue light and strobe light
- Rear view mirrors
- Paper document storage compartment



Easy Service Access
via Back Cover



Ergonomic Operator
Compartment



Informative LCD
Dash Display

Model	Measurement	MT30UX
Power Type		36-Volt
Operator Type		Seated
Rated Capacity	kg	3000
Drawbar Pull, 60min rating	N	750
Max Drawbar Pull, 5min rating	N	☞
Wheelbase	L1 (mm)	1055
Rear Load Distance	L2 (mm)	382
Service Weight	kg	780
Axle Loading, unladen front / rear	kg	310 / 470
Front, Tyre size / type (No. of Wheels)		15x4.5-8 Solid (1)
Rear, Tyre size / type (No. of Wheels)		15x4.5-8 Solid (2)
Wheel Tread, front	mm	n/a
Wheel Tread, rear	W1 (mm)	860
Seat Height / STD	h3 (mm)	910
Coupling Height	h1 / h2 (mm)	280 / 350
Overall Length	L (mm)	1720
Overall Width	W (mm)	968
Overall Height (excluding cab)	H (mm)	1270
Approach Angle	$\alpha 1$ (°)	≥ 54
Departure Angle	$\alpha 2$ (°)	≥ 37
Min Ground Clearance	X (mm)	90
Turning Radius	Wa (mm)	1490
Travel Speed, unladen	km/h	10
Travel Speed, laden	km/h	7
Gradeability, laden / unladen	%	7 / 12
Service Brake / Parking Brake		Hydraulic / Electromagnetic
Drive Control		AC
Drive Motor Rating *S2 60 min	kW	3
Battery Ampere Hours	Ah	250
Battery Weight	kg	202
Sound level at the drivers ear according to EN / DIN 12053	dB (A)	68

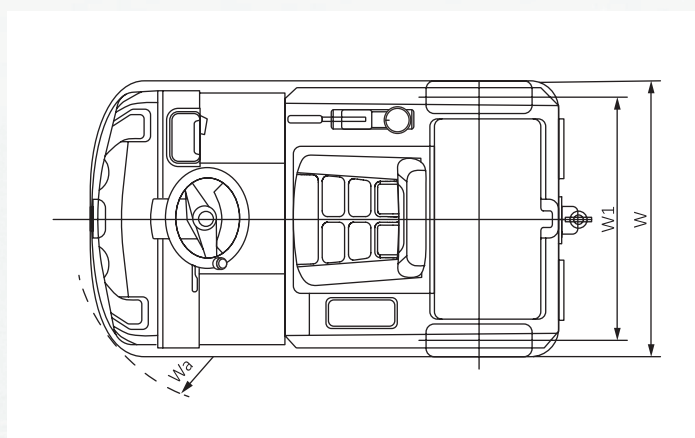
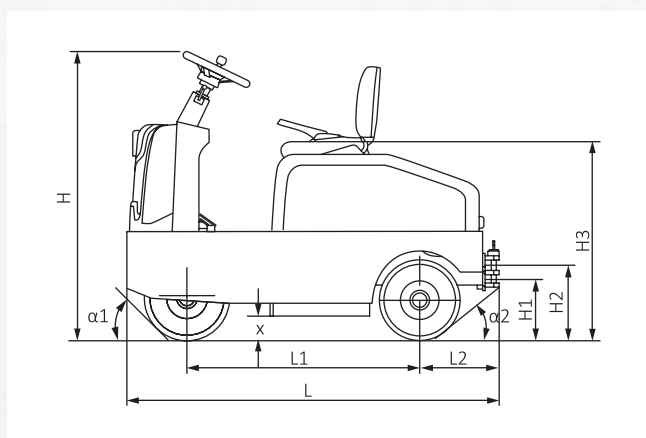

Yale® Dealers



Contact your nearest
Yale® Dealership by visiting
www.yale.com.au

Contact your local Yale® Dealer

Yale Pacific

1 Bullecourt Avenue, Milperra NSW, Australia 2214
Tel: +61 (2) 9795 3800 | Fax: +61 (2) 9792 8484
yale.com/pacific/en-au

Yale Asia

16 Tuas Avenue 20, Singapore 638827
Tel: +65 6863 3387 | Fax: +65 6863 3349
yale.com/asia/en-sg

Yale, and PEOPLE. PRODUCTS. PRODUCTIVITY are trademarks of Hyster-Yale Group, Inc.
® is a registered copyright of Hyster-Yale Group, Inc.

©Yale Asia Pacific 2020. All rights reserved. Specifications and details in this brochure are subject to change without prior notification.

www.yale.com.au



Manufactured in our own ISO 9001 and 14001 Registered Facilities

Trucks may be shown with optional equipment.

Yale® 
People. Products. Productivity.™